

**The**

**HYDROSTAR**

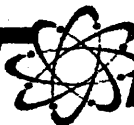

## *Preface*

**Congratulations for investing in your personal copy of The HydroStar System book! I feel fortunate in being given the opportunity to bring this valuable information your way. Now, you too can be involved in efforts to help publicize an incredible and priceless invention; the HydroStar water powered engine!**

**All I ask is that you don't keep this information to yourself; please share it with your friends, relatives, and neighbors. That way we can all be part of the small, but growing, community of thinkers, inventors, and tinkerers determined to bring inventions such as the HydroStar System to the forefront.**

**This book presents complete plans and detailed descriptions sufficient to build a workable HydroStar System. The information contained here has been placed in the public domain, and as such has not been presented as a patented invention. This has been done in hopes of discouraging suppression of such a valuable invention but, even more importantly, to encourage the free flow and dissemination of the HydroStar System information contained within this document. Being a tinkerer at heart, I'm actively involved in building my own HydroStar System. I hope you'll join with me by becoming involved in your own venture; that's what is needed most. Let's all benefit by sharing information and offering encouragement to one another.**

**If you do decide to become involved in your own HydroStar project, or just want to offer advice, an opinion, or constructive criticism on how to improve this book, please feel free to contact me. I'll do my best to get back with you, but I can't guarantee a timely response. Sometimes I'm away from the office for weeks at a time; testing and perfecting new concepts, or just chasing down parts. Here's where you can write me: Power Products, 7017 N Litchfield Rd #388, Glendale, AZ 85307. Or e-mail me: SuperEngines@aol.com.**

**Have fun with your HydroStar project, and happy driving!**

*Bill*

**William S. Power**

# Table of Contents

Preface	Page 1	Toroid Coil	44
Table of Contents	2	Toroid Coil Installation	53
Lots of Questions!	2	Unthreaded Cap Install	56
The HydroStar System!	5	Generator Final Assembly	56
Hydrogen/Oxy Generator	5	In-Dash Panel Assembly	57
Water Tank and Pump	9	Water Tank and Pump	62
In-Dash Indicators	10	HyTronics Module	65
HyTronics Module	11	Carburetor Adapter	68
Let's Build the HydroStar!	18	Throttle Assembly	68
Generator Construction	18	Preliminary Testing	71
Electrodes	18	Cylinder Head Temp	77
Housing Attachments	33	Final Assembly & Test	78
Unthreaded End Cap	36	Helpful Hints and Tips	90
Slosh Shield	39	Garretts' Gadget	93
Flame Arrestor	39	References	93
Water Level Switch Test	42	A Thought or Two	94

## *Lots of Questions!*

A good starting point for understanding the HydroStar System is to answer those questions that I'm asked most often. So, here goes:

### ***What is the HydroStar System, and is it for real?***

A water-fueled engine conversion system is a very simple, but precise definition of the fantastic HydroStar System. The engine operates entirely on hydrogen and oxygen, generated by the electrolysis of water. No petroleum derived fuel or external electrical generating system is used, or even required. The only byproduct resulting from hydrogen and oxygen combustion within the engine, and expelled from the exhaust system, is water. So, it's completely non-polluting, emitting no noxious fumes. In short, the HydroStar System is an absolutely "clean" system; one that's powered by a free and inexhaustible resource; WATER! It has the unique advantage of being able to remove pollutants from the air during combustion; thus helping to clean our environment. The exhaust from the HydroStar System is actually cleaner than most outside air!

The HydroStar System is for real! It is the end result of many years of testing and experimentation with a multitude of hydrogen generating systems based on the principle of electrolysis of water. Water

electrolysis is simply the breaking down of water into its basic hydrogen and oxygen atoms by passing an electric current through it. You don't even have to add an electrolyte (such as acid) to the water to assure electrical conductivity, as is required with a battery; plain old tap water works fine. In fact, electrolysis is in many ways similar to the reaction which occurs within your vehicles' battery. Electrolysis of water is nothing new; it was first accomplished nearly a century ago. But, until the HydroStar System was developed, it required a high voltage power supply and consumed vast amounts of electrical energy. It actually required much more electrical energy than the energy derived from the combustion of the resultant hydrogen and oxygen. In other words, it was an extremely inefficient process that had no practical use.

The HydroStar is the first, and so far only, practical system developed for use in vehicles. The secret of the HydroStar lies within its HyTronic module. It produces relatively low voltage, but uniquely shaped electronic pulses of precise frequency and duration. The overall power consumption of the HyTronic module and the entire HydroStar System is fairly low; actually low enough to be easily powered by your vehicles' alternator or generator, and with enough reserve power left to run all your vehicles other electrical devices.

### ***Is the HydroStar a perpetual motion machine?***

The HydroStar is not a perpetual motion machine. It is a high efficiency, water-fueled, electro-mechanical system capable of producing hydrogen and oxygen in sufficient quantity to power internal combustion engines.

### ***Is the HydroStar safe?***

Vehicles powered by the HydroStar System are inherently safer than existing gasoline powered vehicles. Gas tanks have to hold many gallons of gas in order to allow vehicles to travel great distances. Such large volumes of gas hold tremendous amounts of combustible energy, as is often demonstrated by the fiery results of an accident severe enough to rupture the gas tank. Very little hydrogen has to be stored within the HydroStars' Hydrogen Generator. The only necessary fuel stored in quantity is water; which, of course, is not combustible.

### ***Why is the HydroStar called a conversion system?***

The HydroStar is called a conversion system because it doesn't require removal, modification, or disabling of any of your vehicles' existing systems. Therefore, it allows you to run your vehicle on either its existing gasoline system or the HydroStar System. In the unlikely

event that your HydroStar fails, you can easily switch back to gasoline power. But, you'll soon be getting your HydroStar back into working order. Once you've driven with the HydroStar you'll never be happy with anything else!

### ***How well does the HydroStar Perform?***

A vehicle powered by the HydroStar system is theoretically capable of traveling from 50 to 300 miles on each gallon of water. However, as is true for any engine, actual efficiency depends on many factors such as; driving habits, terrain, vehicle weight and shape, and ability to tweak the system. Exact efficiency is, of course, a moot point since water is basically a free and inexhaustible resource!

### ***Can the HydroStar System be used in other ways?***

Yes, the HydroStar System can provide fuel from water for just about any home appliance requiring natural gas or propane as a source of heat; thereby saving valuable and diminishing natural resources. Space heaters and furnaces are excellent candidates. Stoves and other cooking units such as barbeque grills can also be fueled by the HydroStar. Such applications require a separate power supply to convert your homes 120 volt AC power into the 12 volt DC power required by the HydroStar. You can purchase an inexpensive power supply at any electronics store such as Radio Shack, or have someone familiar with electronics build one for you since the design is very simple. The cost of home electricity used by the HydroStar is insignificant, probably less than \$1 per month in most cases.

### ***Is the HydroStar System difficult to build?***

No, the HydroStar is relatively easy to assemble and very easy to install. No special tools are required. The usual tools and equipment found in a typical home workshop will do the job. Assembling the HyTronic module to achieve its inherent high level of reliability requires care and attention to details, along with average electronics skill at soldering. The only special piece of test equipment you may want to have access to is an oscilloscope. It isn't absolutely necessary, but will help you obtain peak efficiency from the HyTronics module. But, you shouldn't have any problem getting help from a local electronics guru if you don't have an oscilloscope. Most such folks are so fascinated by unusual electronic systems and devices that they would almost be willing to pay you for the privilege of tweaking your HyTronics module!

## ***Can I buy a ready-to-install HydroStar System?***

Right now the HydroStar is not being commercially manufactured. Planning is in the initial stages for producing HydroStar conversion kits for most vehicles and eventually manufacturing the entire system, or at least its' major components. We're hoping to have some prototype kits tested by the end of 2007 and delivery of ready-to-install kits should begin sometime during 2008. Such a venture requires tremendous amounts of time and cash; something such a small group of enthusiasts simply does not have at this time. So, if you want to have your own HydroStar System right away (and I hope you do), you'll have to do what I'm doing myself; build it using the plans and step-by-step directions contained in this book.

## ***The HydroStar System!***

Figure 18 on pages 47 and 48 depicts the entire HydroStar system. While each component is essential to its operation, the heart of the system is the Hydrogen/Oxygen Generator since it converts water into those gases to power your engine. A Water Tank and Pump store and supply water for the Generator. Precise electronic signals from the HyTronics Module initiate and sustain the creation of hydrogen and oxygen within the Generator. An In-Dash Gauge and Indicator Assembly allows you to accurately monitor all aspects of the HydroStar System. Every part of the HydroStar System is ruggedly designed, for long life and reliable operation.

Let's take a closer look at each part of the system to get a basic understanding of how everything works and interacts:

### ***Hydrogen/Oxygen Generator***

Referring to Figure 1 on Page 6, the Hydrogen/Oxygen Generator housing is a round cylinder constructed from high temperature CPVC pipe, a material widely used by the building industry in plumbing systems. CPVC pipe is durable and nearly indestructible. It's also a very "friendly" material in that it's easy to work with and can be used to fabricate other things such as furniture, planters, and housings for just about anything.

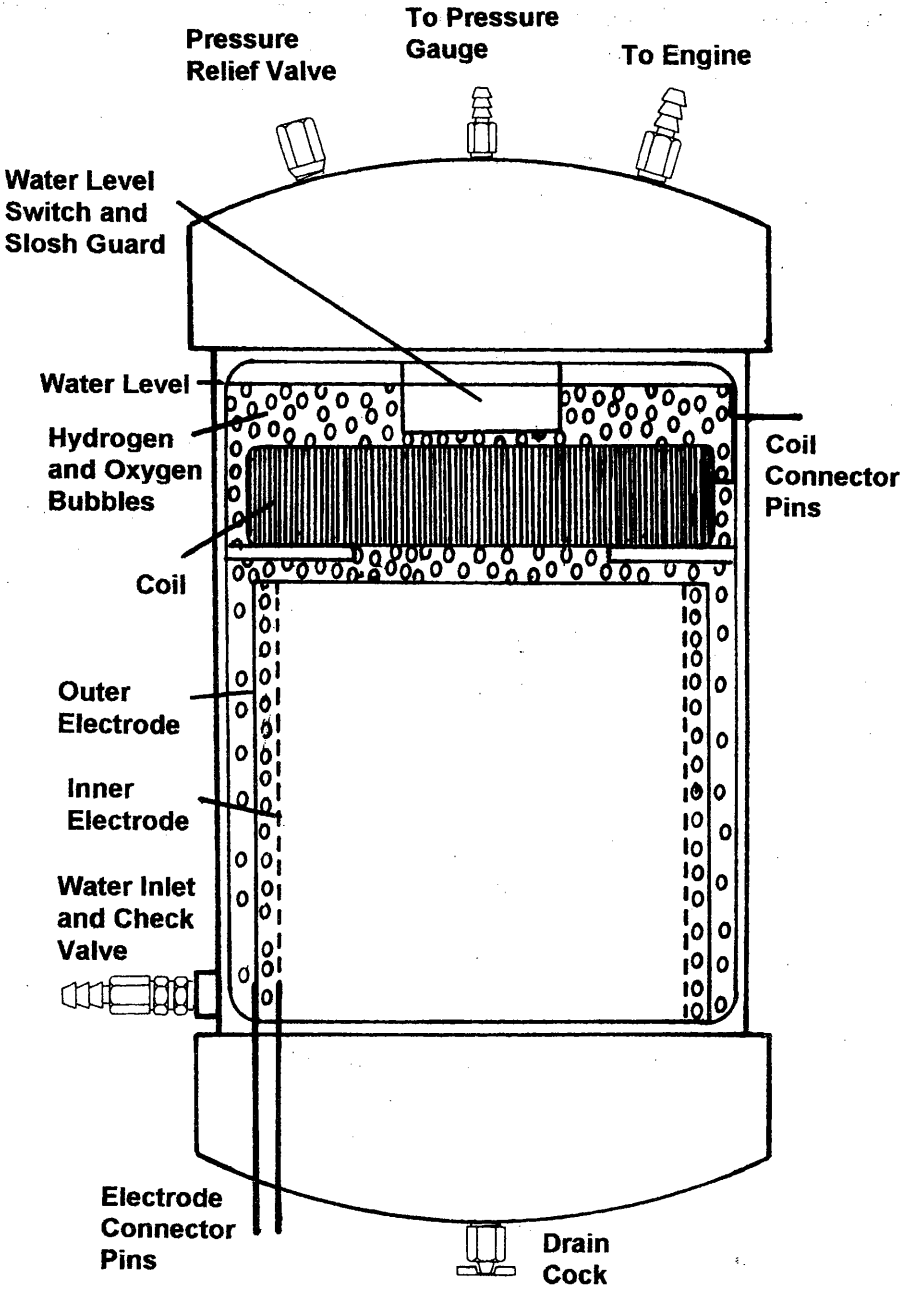

**Hydrogen/Oxygen Generator  
Figure 1**

The Generator housing contains a coil and two cylindrical electrodes; used to generate both hydrogen and oxygen. Each is made from stainless steel and/or ceramic, also very durable materials. However, two atomically different forms of hydrogen are produced within the Generator. Most of the generated hydrogen is orthohydrogen, a very powerful and fast burning gas created by the two electrodes. A precisely controlled, high frequency electronic signal from the HyTronics Module activates and controls the electrodes.

The other form of hydrogen, parahydrogen, is created by the coil, but in much less quantity than orthohydrogen. A precisely controlled, very low frequency electronic signal from a separate circuit within the HyTronics Module activates and controls the coil. Parahydrogen is a less powerful and slower burning gas, but is necessary to prevent precombustion (commonly called "knocking") within your engine. Parahydrogen slows the burning rate of the hydrogen mix, thus boosting its octane level. Such precise control allows you to exactly match your engine's octane requirements. To raise octane levels in gasoline, specific additives must be used to slow its burning rate. At best this is an inaccurate and inefficient method since it depends upon trying to average the octane requirements for millions of engines.

Technically speaking, the Hydrogen/Oxygen Generator itself is an electronic circuit. The two electrodes form a huge capacitor, thousands of times larger than capacitors used in typical circuits, with water acting as its dielectric. The inner electrode is negatively charged, and the outer electrode is positively charged, by the high frequency HyTronics signal. Chemically, each water molecule ( $H_2O$ ) is composed of two positively charged atoms of hydrogen and one negatively charged atom of oxygen. Since opposite charges attract, the positively charged hydrogen atoms are pulled toward the inner electrode. But, at the same instant, the negatively charged oxygen atoms are pulled toward the outer electrode. This action aligns every water molecule between the electrodes, with the ends of each molecule being pulled in opposite directions.

For a few brief moments only more accurate alignment and increased pulling action upon the water molecules occurs. But, the HyTronics signal pulses keep charging the water capacitor to higher and higher voltage levels; actually several thousand volts. Suddenly the electrical forces become so great that the water molecules burst apart (scientists call this action disassociation) into their gaseous forms of hydrogen and oxygen. If you were able to look into the Generator, this action would



be obvious because of the formation of millions of tiny hydrogen and oxygen gas bubbles. As long as the HyTronics signal is applied, the water capacitor remains fully charged; continuously creating orthohydrogen and oxygen.

Another electronic circuit is formed by the Generator coil. This is an inductive circuit, meaning it creates a magnetic field as opposed to the charged field created by the water capacitor. The very low frequency Hytronics signal (actually a short pulse) activates the magnetic field of the coil. As soon as the pulse stops, the magnetic field collapses. This creates an even stronger magnetic field, but a field of opposite polarity. That is how an inductive circuit works, an action commonly called "inductive kick." Each pulse is precisely timed so that almost immediately after the magnetic field reverses, another short pulse arrives. Once again the coil is charged and its magnetic field collapses. But now the continually reversing magnetic field becomes even stronger due to the added energy of each new pulse. Eventually (actually within just a few seconds) the coil reaches its maximum magnetic strength, called its saturation point, which is extremely high.

Most molecules are effected by magnetic fields. The coil's reversing magnetic fields vibrate the water molecules so severely that they disassociate into their gaseous forms of parahydrogen and oxygen. Disassociation obviously occurs, as evidenced by the creation of millions of tiny hydrogen and oxygen gas bubbles around the coil. But the manner in which I've described how it occurs is just one of many theories. Exactly how all this happens is unknown to science since nobody really understands the true nature of magnetism. To this day magnetic force remains a great mystery (as does the nature of gravity); it's there, but why or how is not known.

At this point, we've covered everything needed to understand the basic functioning of the Generator. Every other component of the HydroStar System is simply used to precisely control the action of the Generator. By varying the strength and frequency of the HyTronic signals, the rate at which hydrogen and oxygen are created can be varied to match engine requirements at any particular moment. Water is supplied by the tank and pump, while water level within the Generator is controlled by a level sensor and switch. For safety purposes, a relief valve protects against excess pressure buildup within the Generator. Separate ports are provided for attaching hoses to route gas to the engine and to a gauge to monitor gas pressure within the Generator. A Drain valve is installed to

allow periodic flushing of accumulated minerals and contaminants. The bottom end cap is threaded so that the Generator can be opened up for inspection or repair and for occasional cleaning of the electrodes and coil. Two pairs of stainless steel rods ends protrude from the Generator body to provide electrical connection of the electrodes and coil to the HyTronics Module.

As shown in Figure 18 on pages 47 and 48, the Generator gas output hose connects to a flame arrestor, which in turn connects to pressure fittings attached to the engine. The flame arrestor provides protection against combustion flashback into the Generator in the event that engine backfiring occurs. As with the Generator, the arrestor body is constructed from CPVC pipe. It's a simple unit using small diameter pipe, end caps with hose fittings, and stuffed with stainless steel wool. Pressure fitting kits are readily available at engine high-performance shops. They're designed for converting engines to run on propane, so are perfectly adaptable to the HydroStar System.

I recommend installing the Generator in the engine compartment. It can be installed just about anywhere you can find room in the vehicle, even in the trunk. But, everything is simplified by placing it near the engine since that minimizes routing of hoses, gauge lines, and electrical wiring.

## ***Water Tank and Pump***

Obviously this is the simplest part of the whole system. Just about any large container will hold water, but I'll recommend a particular tank when we get into the construction phase. There are endless ways to save a few bucks here and there while building the HydroStar, but I don't recommend cutting corners if quality is sacrificed. The entire system is designed to be highly reliable, so why take a chance on messing things up by going cheapo? For example, I recommend installing a water level sensor in the water tank so you can easily monitor water quantity, and sensors are relatively expensive. Otherwise you'll have to occasionally compare the miles you've driven versus the quantity of water; with all that based upon the MPG of water consumption. The other alternative is to check the water level fairly often, but someday you'll run the tank dry and wish you had spent the extra money for a sensor and indicator.

It's best to use a relatively large water tank of at least 5-10 gallons capacity. The tank I'll be recommending holds 16 gallons and has translucent level markings, so it's easy to see how much water remains. The few extra gallons of capacity take up very little space, but leaves a good reserve for driving long distances. I recommend installing a 6-inch vent tube into the tank cap to prevent spillage from sloshing water. Because of size, the only practical location for any tank is in the trunk.

You'll also have to decide on pump location. If you use the self-priming pump I recommend, you can mount it in the engine compartment. If you don't use a self-priming pump, you'll have to mount the pump directly onto the tank, or close by, and at a level near the bottom of the tank. Also, if you don't use a self-priming pump, the water hose going from the pump to the Hydrogen/Oxygen Generator will have to be capable of withstanding at least 66 psi water pressure. That's the minimum recommended pump pressure capacity required to overcome maximum gas pressures of 65 psi within the Generator, with an additional 1 psi needed to activate the one-way valve installed on the Generator housing. Also, if you don't use a self-priming pump, you'll have to run an extra power lead back to the trunk. For the sake of simplicity and reliability a self-priming pump is the best way to go.

### ***In-Dash Indicators***

Referring to the following Figure 2; to permit easy monitoring of HydroStar functions, I recommend two gauges: Generator pressure (GEN PRESS) and engine cylinder head temperature (CHT). I also recommend four indicator lights: GEN WATER LOW, PUMP ON, TANK WATER LOW, and PWR ON. These should be installed into your vehicle dash, or mounted in a nearby console.

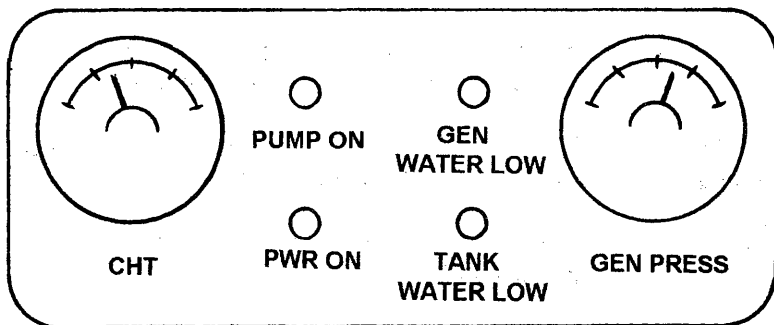

**In-Dash Indicators**  
**Figure 2**

Monitoring the GEN PRESS and CHT gauges allows you to develop a feel for how the system responds to various driving conditions. They can also be of help in tweaking the system to obtain maximum performance and economy.

The GEN WATER LOW light normally remains unlit. As fuel (water) is consumed, the Generator water level gradually drops until the GEN WATER LOW light illuminates. At that point the water pump should start pumping water, illuminating the PUMP ON light. When Generator water has risen back to its normal level, the GEN WATER LOW light should go back out. At the same time, the pump should stop running, turning out the PUMP ON light. So, under normal operating conditions, both lights should be illuminated at the same time, and both lights should go out at the same time. Any other light combination indicates a malfunction.

The TANK WATER LOW light illuminates when tank water level drops to its 1/3 full point, indicating that you should think about filling the tank before long. The PWR ON (Power ON) light should light, and remain lit, as long as the HydroStar System is operating normally. The signal for this light comes from the HyTronics Module. So, if the PWR ON light ever goes out (except when the system is intentionally turned off), or becomes intermittent, the Hytronics Module is malfunctioning.

## ***HyTronics Module***

The HyTronics Module contains electronics circuits for controlling and/or providing power to all the HydroStar electrically operated devices. Separate circuits exist to perform each of the following functions:

- Provide power to the Generator electrodes in the form of a high frequency signal, creating orthohydrogen and oxygen.
- Provide power to the Generator coil in the form of a very low frequency signal, creating parahydrogen and oxygen.
- Control power to the water tank pump via signals received from the Generator water level sensor.

- Provide busing and terminal points for distributing power to system gauges, indicators, and sensors.

## **Generator Electrode Circuit Schematic**

Figure 5 on page 13 depicts the schematic diagram for the Generator electrode circuit. Its output is a square wave pulse which is applied to the cylindrical electrodes of the Hydrogen/Oxygen Generator shown in Figure 18 on pages 47 and 48.

Referring to the following Figure 3, this square wave pulse has an ON:OFF ratio of 1:1. That is, the pulse is turned ON for as long as it's turned OFF. The square wave pulse shown in the following Figure 4 has an ON:OFF ratio of 3:1. That is, the pulse is turned ON for three times as long as it's turned OFF. The Generator electrode circuit of Figure 5 is capable of varying its square wave pulse ratio between 1:1 and 10:1.

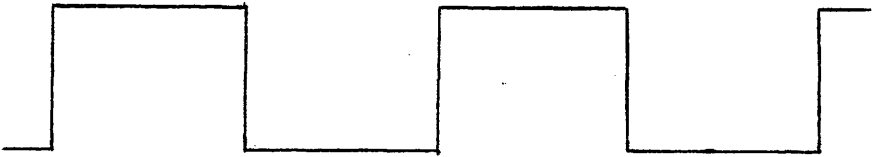

**Square Wave - ON:OFF Ratio 1:1**  
**Figure 3**

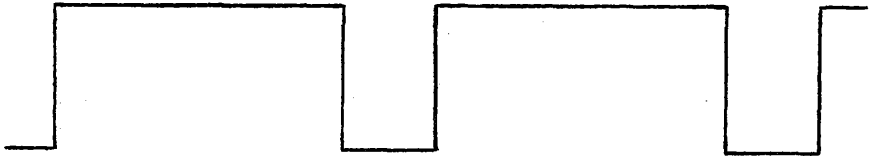

**Square Wave - ON:OFF Ratio 3:1**  
**Figure 4**

Each ON:OFF pulse sequence is referred to as a "cycle" since each new pulse sequence keeps cycling ON and OFF in an identical way. Figure 3 shows three cycles of ON:OFF pulse sequences. If these cycles were all

Generator Electrode Circuit Schematic  
Figure 5

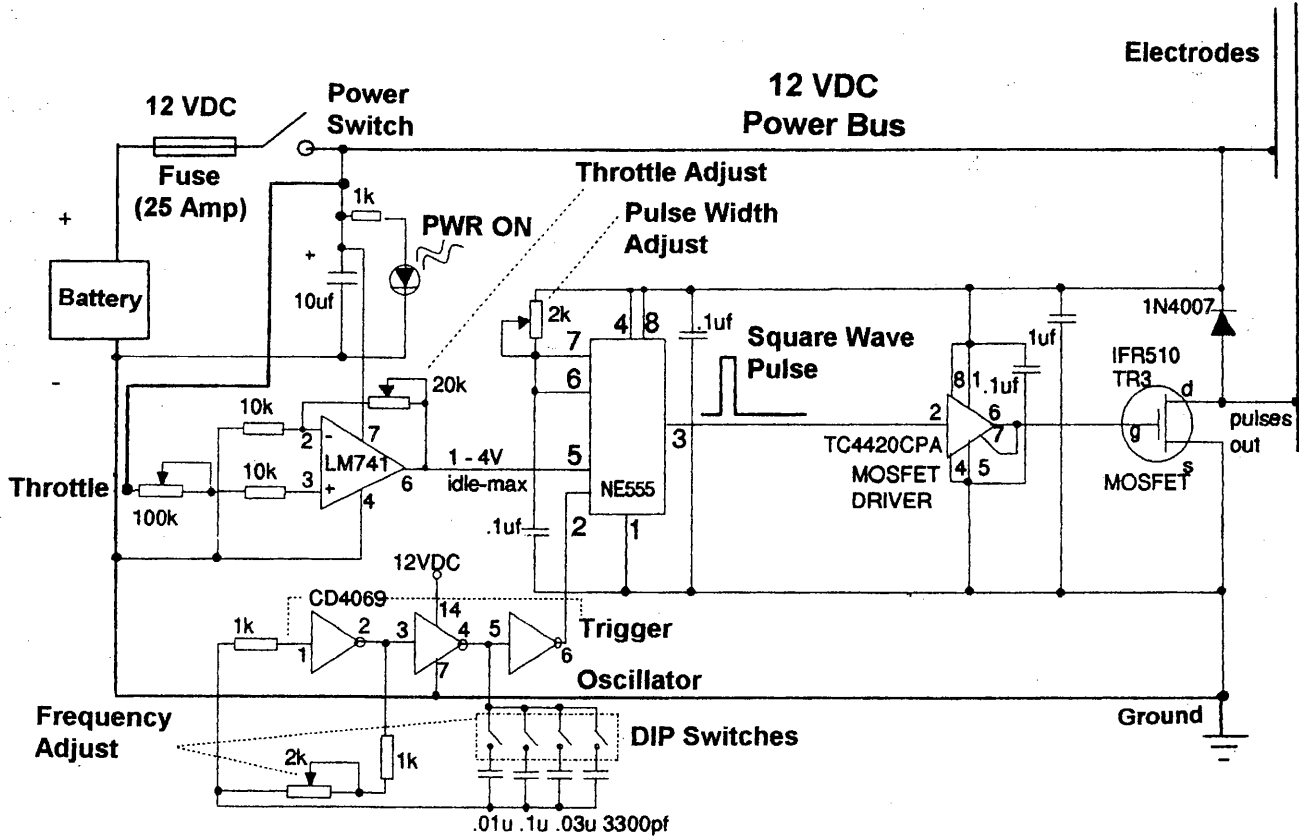

to occur within a time span of one second, we would refer to the pulse as having a frequency of 3 cps (cycles per second). If 127 cycles were all to occur within a time span of one second, we would refer to the pulse as having a frequency of 127 cps. Signal frequencies used to be referred to in exactly that manner (3 cps, 127 cps, etc.). However, because some folks love to change things, the terms used today would be 3 Hz and 127 Hz. The abbreviation Hz is used to honor Mr. Hertz, a scientist who helped pioneer the theories and practical uses of electrical signals. The symbol K is used to denote units of 1,000. Thus, 3,000 Hz would be 3 KHz, and 127,000 Hz would be 127 KHz. The square wave created by the circuit of Figure 5 can be varied in frequency from approximately 8 KHz to 260 KHz.

The square wave pulse ratio determines the amount of current sent to the Generator electrodes by the circuit of Figure 5. If the ratio is low (1:1), very little current arrives at the electrodes. So, very little hydrogen and oxygen are produced by the Generator. If the ratio is high (10:1), maximum current reaches the electrodes and the Generator produces maximum gas volume. Varying voltage input from a potentiometer connected via a 10K resistor to pin 3 of component LM741 causes the circuit to vary the pulse ratio, and therefore controls the amount of gases produced. The potentiometer shaft connects to the vehicle throttle linkage, enabling control of gas volume in direct response to voltage changes correlating with rotation of the potentiometer shaft in relation to throttle positioning. A trimming potentiometer connects pins 2 and 6 of component LM741, enabling precise adjustment of the throttle input signal. A second trimming potentiometer connects pins 4 and 7 of component NE555, enabling precise pulse width adjustment.

The electrode pairs of each Generator exhibit a unique frequency of electrical resonance at which optimum gas volume is created. This frequency often varies considerably among different Generators. Several factors determine resonance frequency such as: electrode size and shape, Generator chamber size and shape, spacing between electrodes, coil parameters and relative positioning, and pulse amplitude (voltage level). A trimming potentiometer connected between pins 1 and 2 of component CD4069 allows the precise frequency to be obtained. By selecting various combinations of dipswitch connections to a bank of four capacitors, pulse frequency can be varied between approximately 8 KHz and 260 KHz.

## Generator Coil Circuit Schematic

The following Figure 6 depicts the schematic diagram for the Generator coil circuit. Its output is a square wave pulse which is applied to the coil of the Hydrogen/Oxygen Generator shown in Figure 18 on pages 47 and 48.

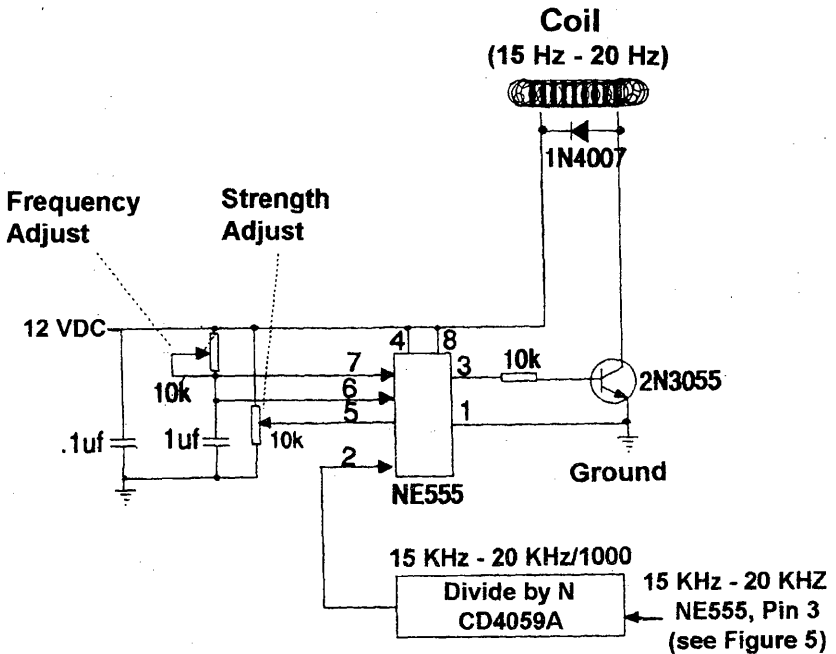

**Generator Coil Circuit Schematic**  
**Figure 6**

The Generator coil circuit creates a pulsed signal very much similar to that of the electrode circuit of Figure 5; but, production of parahydrogen and oxygen by the coil entails totally different operating parameters than does orthohydrogen and oxygen production by the electrodes. Optimum operating frequency for the coil is much lower, within the range of approximately 16 Hz to 25 Hz. Coil frequency directly correlates to the optimum operating frequency of the electrode circuit since its input signal is received directly from pin 3 of electrode circuit component NE555. The electrode circuit signal is received via the "Divide by N" logic circuit which produces one output signal in response to a specific number of input signals. For example, if the optimal frequency of the



electrode circuit is 19 KHz and the "Divide by N" logic circuit creates one output pulse for every 1,000 input pulses, the output frequency of the "Divide by N" logic circuit would be 19 Hz. That signal is received via pin 2 of component NE555, which creates the required square wave pulses. Those pulses are sent via pin 3 to the base of transistor 2N3055, where they are amplified and transmitted to the coil.

The volume of parahydrogen and oxygen created by the coil can be precisely regulated by adjusting the pulse width and amplitude trimmer potentiometers of its associated circuit. Parahydrogen acts as an octane booster. Therefore, the volume required depends entirely upon the operating demands of your engine. Since parahydrogen cools the combustion process, excess volume tends to reduce engine efficiency. With that in mind, the coil circuit should be adjusted such that only enough parahydrogen is created to prevent engine precombustion (knocking). However, if engine operating temperature is running on the high side (as determined by the CHT gauge) increasing parahydrogen volume is an effective way to lower the temperature.

### ***In-Dash Indicators Circuit Schematic***

The In-Dash Indicators Circuit schematic is depicted by Figure 7 on page 17. Two gauges and four light emitting diodes (LED's) comprise the In-Dash Indicators assembly. The Generator pressure (GEN PRESS) gauge connects via a hose to its respective fitting on the Generator itself (refer to Figure 13 on pages 37 and 38). The cylinder head temperature (CHT) gauge electrically connects to a sensor placed under an engine spark plug.

When the Generator water level sensor is activated by low water level, its 12 VDC signal is sent to pin 2 of detector LM741 via a 10K resistor. Detector output from pin 6 triggers the base of power transistor E3055T, completing the circuit to activate the water pump and illuminate the "PUMP ON" LED. The 12 VDC sensor signal also illuminates the "GEN WATER LOW" LED. When Generator water rises to its normal level, the level sensor opens; turning off the pump and both LED's.

When the tank water level sensor is activated by low water level (at 1/3 tank level), its 12VDC output signal illuminates the "WATER LOW" LED. After refueling (adding water), the level sensor opens, turning

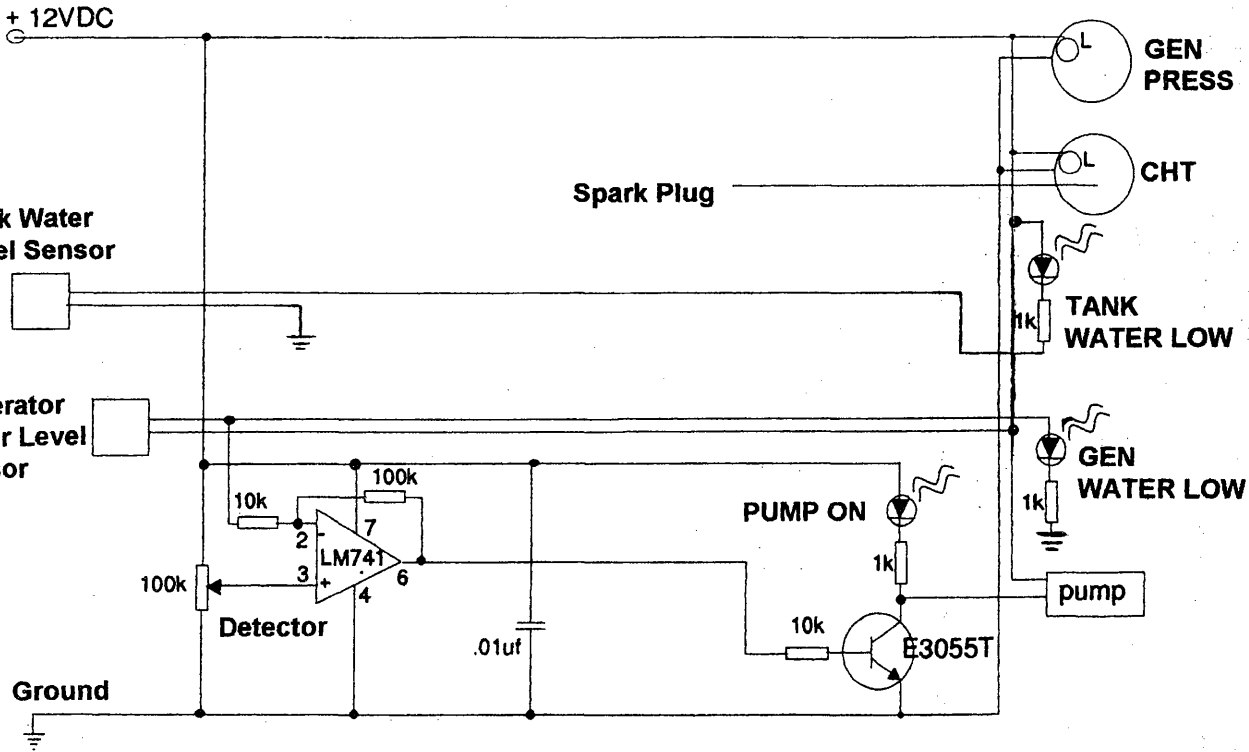

**In-Dash Indicators Circuit Schematic**  
**Figure 7**

off the LED.

When the HydroStar System is turned on, the "PWR ON" LED illuminates. The Generator electrode circuit (see Figure 5 on page 13) activates the LED. Failure of the LED to illuminate usually indicates an electrode circuit malfunction.

## *Let's Build the HydroStar!*

### **Generator Construction**

#### **Electrodes**

Since engine requirements dictate the volume of hydrogen and oxygen gases that the Generator must create, and gas volume is variable, I recommend sizing it as large as is practical to allow reserve capacity. Maximum outside diameter of 4.5" is already determined by the construction material used for the Generator housing: 4" CPVC Schedule 80 pipe. I recommend a minimum height of 10". Maximum height depends upon available space within the engine compartment but, for structural integrity, limit height to 18". Carefully check the engine compartment of your vehicle to ensure that adequate space exists for Generator installation. If adequate space does not exist either limit the Generator height (but not less than 10"), or locate the Generator within the trunk, or as far forward as possible under the dash.

**CAUTION:** IT MAY BE POSSIBLE TO OBTAIN 3-1/2" OUTSIDE DIAMETER STAINLESS STEEL TUBING WITH A WALL THICKNESS OF .040" TO .063" AND T304 ALLOY AT A LOCAL SHOP THAT MANUFACTURES EXHAUST AND/OR MUFFLER SYSTEMS. ALL TUBE DIMENSIONS, INCLUDING ROUNDNESS, MUST BE HELD WITHIN .005" THROUGHOUT ITS ENTIRE LENGTH. DO NOT USE CHEAP TUBING. IF YOU DO, THE EFFICIENCY OF THE HYDROSTAR SYSTEM WILL BE SEVERELY DEGRADED. IF YOU ARE UNABLE TO OBTAIN HIGH QUALITY TUBING LOCALLY, I RECOMMEND THE FOLLOWING SOURCE:

**Eagle Stainless  
Tube & Fabricating, Inc  
10 Discovery Way  
Franklin, MA 02038**

**Phone: 1-800-528-8650**

**Local Phone: 508-528-8650**

**FAX: 1-800-520-1954**

**Local FAX: 508-520-1954**

1. After determining Generator height, obtain a 3-1/2" (3.50") outside diameter stainless steel tube with wall thickness of .040" to .063" and length 5" shorter than the determined height of the Generator. A standard alloy of T-304 stainless steel is recommended for the electrodes. This tube will be used to construct the outer electrode. Refer to the Generator exploded view of Figure 9 on page 24 as an aid to correct construction.

**NOTE:** The following steps 2 through 4 will be used to determine the outside diameter for the inner electrode. This procedure will create a .045" gap between the inside wall of the outer electrode and the outside wall of the inner electrode. This value is an ideal gap for maximum and most efficient production of hydrogen and oxygen gases with the HydroStar System.

2. Multiply the wall thickness of the outer electrode by a factor of 2 and record the result as dimension A. For example, if the wall thickness is .050", dimension A would be .100".

3. Add a value of .090" to the value of dimension A and record the result as dimension B. For example, if dimension A is .100", dimension B would be .190".

4. Subtract the value of recorded dimension B from 3.50". Record this value as dimension C. For example, if dimension B is .190", dimension C would be 3.31".

**NOTE:** The CAUTION of page 18 also applies to the inner electrode.

5. To construct the inner electrode, obtain a stainless steel tube with an outside diameter equal to the recorded dimension C, with wall thickness of .040" to .063", T304 alloy, and length equal to that of the outer electrode.

6. Referring to the following Figure 8, drill eight (8) 1/4" holes, spaced at 45 degree intervals, around the diameter of one end of the outer electrode tube. Locate the hole centers 11/32" from the tube edge. Clamp a large diameter wood dowel or rod in a vise to back up the electrode while drilling. Deburr the holes after drilling.

**NOTE:** For best results, drilling stainless steel requires a carbide-tipped drill bit and light lubricating oil. Take your time drilling so as not to overheat the electrode.

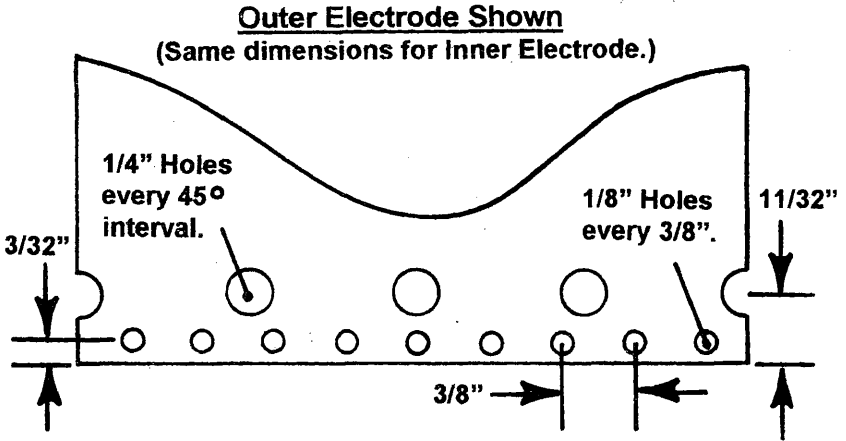

**Electrode Details**  
**Figure 8**

7. Repeat the procedure of step 6 to drill eight (8) 1/4" holes at the same distance from the end of the inner electrode tube.

8. Referring again to Figure 8, drill 1/8" holes around the end of the outer electrode closest to the 1/4" holes. Locate the hole centers 3/32" from the tube edge, with hole centers spaced at 3/8" intervals around the entire diameter. Deburr the holes after drilling.

9. Repeat the procedure of step 8 to drill 1/8" holes around the entire diameter of the end of the inner electrode. Deburr the holes after drilling. Thoroughly clean all oil residue from both electrodes using a soft clean cloth, and MEK or acetone as a cleaning solvent.

**NOTE:** Bare stainless steel welding rod, T304 alloy, can be obtained at any welding supply store.

10. Referring to Figure 8, cut two (2) 3" rod lengths from 3/32" diameter bare stainless steel welding rod, alloy T304. Using a file, square off and deburr the rod ends.

**NOTE:** Silver-bearing solder and flux can be purchased at any large hardware or electrical supply store.

11. Referring to Figure 8, solder one of the rods to the outside surface of the outer electrode. Position the rod parallel to the length of the electrode with 2" protruding past the end of the tube. Use silver-bearing solder and flux appropriate for soldering stainless steel.

12. Repeat the procedure of step 11 to solder the other rod to the inside surface of the inner electrode.

13. After the electrodes have cooled, thoroughly scrub the solder joints with warm soapy water using a stiff-bristle brush. Thoroughly rinse the electrodes with warm water and dry with a soft clean cloth.

## Housing

**CAUTION:** USE CPVC PIPE (SCHEDULE 80) TO CONSTRUCT THE GENERATOR HOUSING. DO NOT USE PVC PIPE, OR CPVC SCHEDULE 40, SINCE IT WILL NOT WITHSTAND HIGH TEMPERATURE OR PRESURE AS WELL.

**CAUTION:** DO NOT USE CPVC PIPE OF SIZE GREATER THAN 4" SINCE IT DOES NOT OFFER AN ADEQUATE SAFETY MARGIN AGAINST RUPTURE WHEN SUBJECTED TO HIGH PRESSURE AND TEMPERATURE.

**CAUTION:** CAREFUL ATTENTION TO CRAFTSMANSHIP AND DETAIL DURING GENERATOR CONSTRUCTION IS ESSENTIAL TO ENSURE SAFE AND RELIABLE OPERATION.

**NOTE:** Any large plumbing supply or plastics supplier may be able to supply CPVC Schedule 80 pipe, fittings, and accessories required to construct the HydroStar Generator. I highly recommend United States Plastic Corporation as an excellent source; they have always provided me with friendly and dependable service over the years, and they stock everything you'll ever need. You may want to order a copy of their excellent catalog using their toll-free Customer Service phone number.

**Mail Orders:**

**United States Plastic Corp  
1390 Neubrecht Rd  
Lima, OH 45801-3196**

**Phone Orders: 1-800-537-9724 (7:30am - 7pm EST, Mon - Fri)**

**FAX Orders: 1-800-854-5498 (24/7)**

**Technical Service: 1-800-821-0349 (8am - 5pm EST, Mon - Fri)**

**Customer Service: 1-800-769-1157 (8am - 6pm EST, Mon - Fri)**

**List of materials:**

- One CPVC 4" threaded pipe nipple, length 12", Schedule 80 (US Plastic Stock #: 30314).
- One CPVC 4" pipe, length 12", Schedule 80 (US Plastic #: 29022) (Only needed if housing height exceeds 10").
- One CPVC 1-1/2" pipe, length 12", Schedule 80 (US Plastic #: 29018).
- Two CPVC 4" Straight Couplings, Schedule 80 (US Plastic #: 30059) (Only one needed if housing height will be 10")
- One CPVC 4" cap, Schedule 80 (US Plastic #: 30047).
- One CPVC 4" threaded cap, Schedule 80 (US Plastic #: 29147).
- One 1/8" thick, 24" x 48", CPVC sheet (US Plastic #: 45299)
- One 1" diameter, 6" length, CPVC rod (US Plastic #: 43183)
- One pint can of CPVC cement (US Plastic #: 29053).
- One pint can of primer (US Plastic #: 28292).
- One 8 ounce can of pipe joint compound (US Plastic #: 16532).

1. CPVC 4" Schedule 80 pipe is used to construct the Generator housing. Since one end of the pipe will require threading, I recommend purchasing a 12" threaded pipe nipple rather than thread a pipe yourself. Refer to the Generator Details view of Figure 10 on page 26 as an aid to construction.

**NOTE:** CPVC 4" Schedule 80 pipe has an outside diameter of 4.5".

**NOTE:** If the height of the housing will be 10", as determined during the procedure at the beginning of the "Electrodes" section on page 18, follow the directions of step 2, then go to step 8. If the height will be greater than 10", go to step 3.

2. Using a miter box or table saw to assure squareness, cut off one of the 12" pipe nipple threaded ends 2-3/4" from the end. Dress the cut edges with sandpaper or a fine-tooth file. Go to step 8.

3. Using a miter box or table saw to assure squareness, cut the threaded pipe nipple 5-1/2" from one of its threaded ends. Dress the cut edges with sandpaper or a fine-tooth round file.

**CAUTION: READ DIRECTIONS PRINTED ON THE PRIMER AND CEMENT CAN LABELS FOR PROPER USE OF THE PRODUCTS. AFTER PRIMING, APPLY CEMENT AS SOON AS POSSIBLE. TO OBTAIN SAFE AND RELIABLE BONDING, DO NOT LET THE PRIMER DRY BEFORE APPLYING CEMENT.**

4. Prime the outside mating surface of the cut end of the 5-1/2" pipe nipple and one of the inside mating surfaces of the coupling. Apply an even layer of cement to the primed surfaces and assemble the parts. Allow the parts to air dry for at least 10 minutes before going to step 5.

5. Prime the outside mating surface of the 12" pipe and inside mating surface of the coupling attached to the pipe nipple. Apply an even layer of cement to the primed surfaces and assemble the parts. Allow the parts to air dry for at least 30 minutes before going to step 6.

6. If the height of the housing is to be 18", go to step 8. If the height is to be less than 18", go to step 7.

7. Using a miter box or table saw to assure squareness, cut the pipe assembly near the unthreaded end to form a total pipe length equal to 1/2" less than the housing height. Dress the cut edges with sandpaper or a fine-tooth round file.

8. Measure the inside diameter of the threaded end cap. Securely clamp 1/8" thick CPVC sheet to a drill press bed. Drill a 1/2" diameter hole through the sheet. Using a fly cutter, cut a disk with the measured diameter. Check that the disk fits snugly into the end cap. If loose, replace with a slightly larger disk. If tight, replace with a slightly smaller disk. Be sure to drill a 1/2" hole first if a new disk is cut. Cut a second disk to the correct diameter with 1/2" center hole.

9. Apply primer, and then cement, to one surface of each disk and join the disks together. Align the disk edges and wipe excess cement from the edges. Allow the disks to air dry for an hour before going to step 10.

10. Referring to Figure 9 on page 24, bevel the edges of the disk to fit the curved contour of the bottom of the end cap. Be sure the outer edge of



the disk measures between 1/32" and 1/16" after beveling.

**CAUTION: THE ELECTRODES WILL BE ATTACHED TO THE CONTOURED DISK. FORM THE CONTOUR ACCURATELY TO ASSURE STRUCTURAL INTEGRITY OF THE HYDROSTAR.**

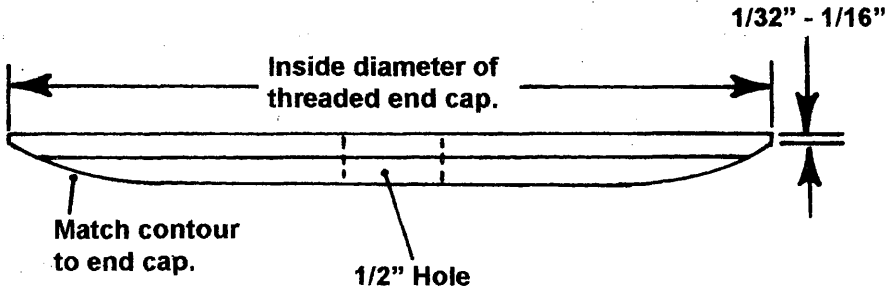

**Disk Contour  
Figure 9**

**CAUTION: THE END CAP WILL BE TEMPORARILY THREADED ONTO THE HOUSING TO ASSURE ACCURATE ALIGNMENT OF THE DISK. DO NOT USE EXCESSIVE CEMENT WHEN INSTALLING THE DISK TO PREVENT BONDING OF THE HOUSING AND END CAP THREADS.**

**CAUTION: BE SURE PETROLEUM JELLY COATS ONLY THE END CAP THREADS.**

11. Lightly coat the threads of the housing and end cap, and bottom edge of the housing, with petroleum jelly. Apply primer to the mating surfaces of the disk and end cap. Apply cement to the primed area of the end cap only and install the disk, seating it firmly and evenly. Remove any cement that oozes from between the parts with cotton swabs.

12. Temporarily thread the end cap onto the housing, seating it slowly, but firmly. Wait about 15 minutes for the cement to partially dry and then remove the end cap.

**CAUTION: BE SURE TO MEASURE THE INSIDE DIAMETER OF THE UNTHREADED END CAP BEFORE CUTTING DISKS.**

13. Repeat the procedure of the preceding steps 8 through 10 for the

unthreaded end cap. There's no need to apply petroleum jelly to any areas of the unthreaded end cap. Apply primer to the mating surfaces of the disk and end cap. Apply cement to the primed area of the end cap only and install the disk, seating it firmly and evenly. Remove any cement that oozes from between the parts with cotton swabs.

14. Seal the 1/2" hole in the threaded end cap disk with electrical tape. Using a stiff bristle brush and warm soapy water, thoroughly clean petroleum jelly from the threads and all other areas of the end cap and housing. Rinse all parts with warm water.

15. Repeat step 14, and then wipe the parts dry with a soft clean cloth.

16. Remove the electrical tape from the threaded end cap. Allow the end caps to air dry for at least 8 hours before going to step 17.

17. Completely cover the inside surfaces of both end caps with strips of electrical tape. Cut away tape to open up the 1/2" hole in each disk.

**NOTE:** The cavity in each end cap will be filled with epoxy cement. To prevent trapping air bubbles, the caps must remain level while the epoxy cures. Centering and leveling the curved caps on the inner cores of large rolls of tape works well.

**CAUTION:** USE ONLY HIGH QUALITY, HIGH TEMPERATURE, AND WATERPROOF EPOXY CEMENT TO FILL THE END CAP CAVITIES. USING ANY OTHER CEMENT MAY LEAD TO EVENTUAL FAILURE OF THE HYDROSTAR GENERATOR.

18. Purchase a high quality, high temperature, and waterproof epoxy cement to fill the end cap cavities. I highly recommend J-B WELD, which can be purchased at any large hardware or auto supply store. It comes packaged in two 2-ounce tubes (one tube resin and one tube hardener). You will probably need at least one package to fill each end cap. If you have questions about J-B WELD, they can be contacted at:

J-B WELD  
PO Box 483  
Sulphur Springs, TX 75483  
(Information continued on page 27.)

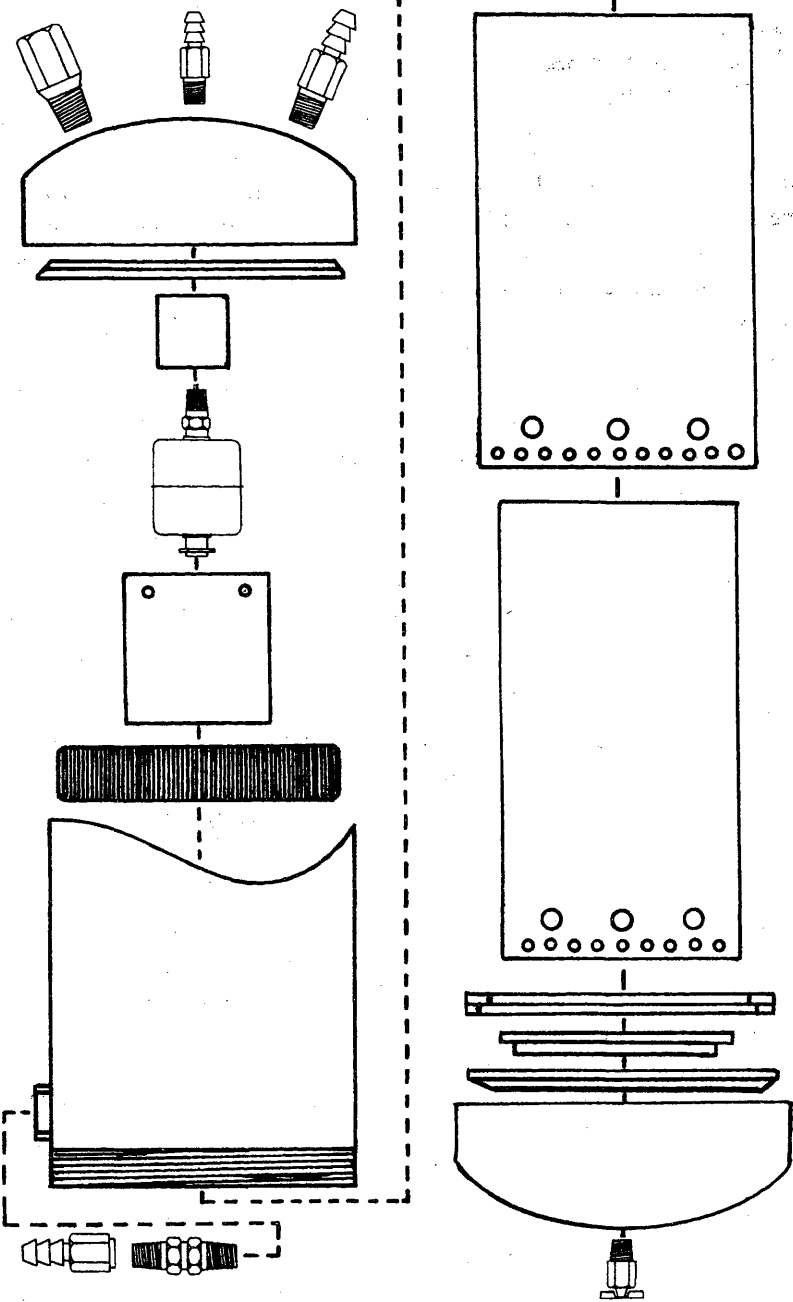

**Generator Details  
Figure 10**

Phone: 1-903-885-7696  
Toll Free: 1-800-529-3530  
Fax: 1-903-885-5911

**NOTE:** All epoxy cements cure by chemical reaction (after the hardener is mixed with resin). J-B WELD remains pliable for about 30 minutes. There's no need to rush filling the end cap cavities, but be aware that once the cement is mixed, there's no stopping it from curing. If you have to remove or adjust anything after it cures, you'll need dynamite to get things apart.

**NOTE:** Be sure to mix equal amounts of resin and hardener (if using J-B WELD). The resin and hardener are different colors; one black and one white to avoid confusion. When mixed properly, you end up with a nice dark gray cement. If you accidentally mix resin with resin, or hardener with hardener, you end up with nothing but a big mess.

19. Mix about a 4-ounce batch of epoxy in a disposable container such as a small paper cup. Slowly fill the cavity (to avoid trapping air bubbles) to the top of the 1/2" hole in one of the end caps. If necessary, mix more epoxy.

**NOTE:** Be sure you have enough epoxy on hand to totally fill the remaining cavity. If not, purchase more before starting. After epoxy cures, it has very poor adhesion with newly mixed epoxy.

20. Repeat step 19 to fill the remaining end cap cavity.

21. Allow the epoxy to cure for at least 24 hours. Remove all electrical tape from the end caps. Remove any epoxy from above the top of the 1/2" hole until flush with the disk surface by grinding, scraping, sanding, or doing whatever is required.

22. Measure the inside diameter of the inner electrode. Record this measurement as dimension D.

23. Securely clamp 1/8" thick CPVC sheet to a drill press bed. Using a fly cutter, cut a disk with diameter equal to dimension D from the sheet. Check that the disk slides easily into the end of the inner electrode opposite the soldered rod, being neither loose nor tight. If loose, replace with a slightly larger disk. If tight, replace with a slightly smaller disk.

24. Subtract the value of .250" from the recorded dimension D. Record this new value as dimension E. For example, if dimension D is 3.21", dimension E would be 2.96".

25. Securely clamp 1/8" thick CPVC sheet to the drill press bed. Using a fly cutter, cut another disk with diameter equal to dimension E.

**CAUTION: READ DIRECTIONS PRINTED ON THE PRIMER AND CEMENT CAN LABELS FOR PROPER USE OF THE PRODUCTS. AFTER PRIMING, APPLY CEMENT AS SOON AS POSSIBLE. TO OBTAIN SAFE AND RELIABLE BONDING, DO NOT LET THE PRIMER DRY BEFORE APPLYING CEMENT.**

26. Apply primer, and then cement, to one of the flat surfaces of each disk. Join the disks, centering the smaller disk on the larger disk.

**NOTE:** The procedure of steps 27 and 28 will be used to cut a flat ring from CPVC sheet. Do not unclamp the sheet from the drill press bed until step 28 has been completed.

27. Securely clamp 1/8" CPVC sheet to the drill press bed, centering the cutter at least 3" from any edge of the sheet. Cut a 3-1/2" hole in the sheet.

28. Adjust the cutter to cut a ring with an outside diameter of 3-15/16".

29. Check that the ring slides easily onto the end of the outer electrode opposite the soldered rod, being neither loose nor tight. If loose, replace with a ring of slightly smaller inside diameter. If tight, replace with a ring of slightly larger inside diameter.

30. Repeat the procedure of step 27 to cut a 3-5/8" hole into 1/8" thick CPVC sheet.

31. Repeat exactly the procedure of step 28.

32. Apply primer, and then cement, to one of the flat surfaces of each ring. Join the rings, aligning the outer edges. Wipe any excess cement from the outer edges. Allow the rings to air dry at least 30 minutes before going to step 33.

33. Grind a small notch into the inner edge of the rings just large enough to allow the rings to clear the soldered rod and solder when slid onto the

rod end of the outer electrode.

**NOTE:** The procedure of step 34 centers the rings within the threaded end cap. Be sure the wrapping tape does not protrude below the edge of the smaller ring at any point. Do not overlap tape ends if more tape is added; simply butt the tape ends before continuing to wrap.

34. Using plastic electrical tape, wrap the outer edges of the rings until they slide easily into the threaded end cap. If the rings fit loosely, add more tape. If the rings fit tightly, remove tape.

**NOTE:** Refer to the following Figure 11 for details related to installing the rings into the threaded end cap. Apply primer only to the flat surface of the threaded end cap contacted by the smaller ring. Do not remove the tape until instructed to do so.

35. Apply primer to the flat surface of the smaller ring. Using a cotton swab, apply primer to the flat surface of the threaded end cap contacted by the smaller ring. Apply a thin, even layer of cement to the primed surfaces and install the ring assembly into the end cap. Allow the parts to air dry before going to step 36.

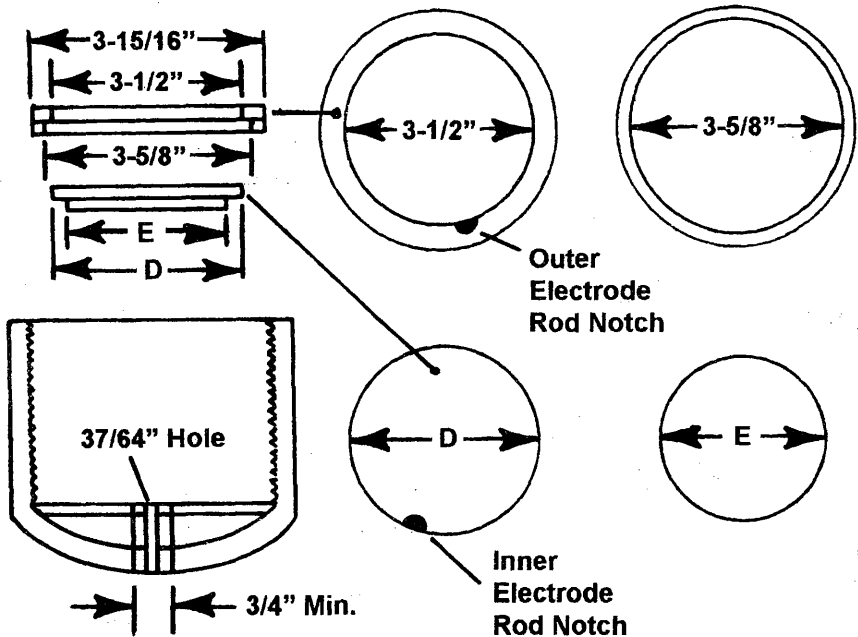

Threaded End Cap Details  
Figure 11

**NOTE:** The procedure of step 36 centers the disks completed in step 26 within the threaded end cap. Be sure the wrapping tape does not protrude below the surface of the small disk at any point. Do not overlap tape ends if more tape is added; simply butt the tape ends before continuing to wrap. Refer to Figure 11 on page 29 for details related to installing the disks into the threaded end cap.

36. Using plastic electrical tape, wrap the edge of the large disk until the tape creates a snug fit with the inside edge of the ring assembly.

**NOTE:** Be sure to align the disks with their notch offset at least 3/4" from the ring notch, as shown in Figure 11.

37. Apply primer to the flat surface of the small disk and the flat inside surface of the threaded end cap. Apply an even layer of cement to the primed surfaces and install the disk assembly into the end cap. Align the disks with their notch offset at least 3/4" from the ring notch, as shown in Figure 11. Using a large C-clamp, lightly clamp the disks and end cap. Allow the parts to air dry at least 8 hours before going to step 38.

38. Remove all electrical tape from the threaded end cap assembly. Scrape away any excess cement that may have oozed onto the flat inside surface of the end cap in those areas that will contact the bottom edges of the electrodes and threaded end of the housing.

39. Drill a 3/64" hole through the center of the threaded end cap as shown in Figure 11.

**NOTE:** Threads will be tapped later into the hole drilled through the center of the end cap to attach the drain cock.

Using a #41 bit, drill two holes through the bottom of the threaded end cap at the locations shown in Figure 11.

40. Temporarily align each electrode and rod with its respective hole drilled in step 39. Check that each electrode and rod can be installed into the threaded end cap and seated firmly on the cap surface. Make adjustments as necessary to achieve correct seating of the electrodes.

Using a marking pen, mark a short reference line near the top inside of the inner electrode. Mark another short reference line near the top inside of the outer electrode, aligning it with the mark on the inner

**electrode:** Remove the electrodes from the end cap.

**NOTE:** The procedure of step 41 centers the inner electrode within the outer electrode. Do not overlap tape ends if more tape is added; simply butt the tape ends before continuing to wrap.

41. Using plastic electrical tape, wrap the top end of the inner electrode until it fits snugly into the outer electrode. Allow about 1/4" of the tape to protrude above the edge of the electrode to facilitate easy removal. Do not remove the tape until instructed to do so.

42. Arrange a way to solidly support the threaded end cap while installing the electrodes and while the epoxy cures (takes about 8 hours). Centering and leveling the curved cap on the inner core of a large roll of tape works well.

43. Once again, clean the bottom ends of the electrodes with MEK or acetone using a soft clean cloth.

44. Seal the bottoms of the two holes in the end cap with short strips of electrical tape to prevent epoxy from dripping out. The tapes will be pushed aside as the electrode rods poke through, after which the tapes can be removed.

45. Mix up about a 2-ounce batch of epoxy in a disposable container such as a small paper cup. Fill the slot in the end cap (where the electrodes are installed) all the way around to about its half-full level.

**NOTE:** Be sure to install the outer electrode first.

46. Using your finger, apply a very thin, but unbroken, coat of epoxy completely around the bottom edge (rod end) of the outer electrode. Form a band extending about 1/4" high from the bottom edge, coating both the inside and outside surfaces of the electrode.

**CAUTION:** THE SMALL HOLES AROUND THE BOTTOM EDGES OF THE ELECTRODES HELP SECURE THE ELECTRODES TO THE END CAP BECAUSE EPOXY FILLS THE HOLES. INSTALL THE ELECTRODES SLOWLY INTO THE END CAP SLOT SO AS NOT TO TRAP AIR BUBBLES WITHIN THE HOLES.



47. Install the outer electrode into the end cap. As the electrode starts to enter the slot, lower it very slowly so that the epoxy has sufficient time to flow into the small holes drilled around the bottom edge without trapping air bubbles. After the electrode is firmly seated onto the end cap surface, remove the tape from the bottom of the end cap.

48. Apply a thin film of petroleum jelly to the surface of the tape wrapped around the top of the inner electrode.

49. Repeat the procedures of steps 46 through 48 to install the inner electrode into the end cap. Use the alignment marks on the tops of the electrodes as an aid in locating the rod hole in the end cap.

50. Place about five pounds of weight on top of the electrodes to help keep them firmly seated against the end cap. Folding a towel or two into several folds and placing them on top of the electrodes, with a stack of hardcover books on top, works well. That method distributes the weight evenly, which can otherwise be difficult because of the tape protruding from the top of the inner electrode.

51. Using cotton swabs, remove any excess epoxy oozing from the eight 1/4" holes around the bottoms of the electrodes. If necessary, continue to do this until the epoxy begins to thicken (in about 30 - 45 minutes). Using household tissues or disposable rags, clean epoxy from the rod ends protruding through the end cap, and from the surrounding surface of the end cap.

**CAUTION: ALLOW THE EPOXY TO CURE FOR AT LEAST 24 HOURS AT TEMPERATURES OF 70 DEGREES OR HIGHER BEFORE REMOVING THE ELECTRODE WEIGHTS OR OTHERWISE DISTURBING THE ELECTRODE ASSEMBLY. FOR LOWER TEMPERATURES ALLOW EVEN LONGER CURE TIME.**

52. Remove the weights from the electrode assembly after the epoxy has cured for at least 24 hours, and remove the tape from the inner electrode.

Using #400 grit (or finer) sandpaper, remove epoxy residue from the rod ends protruding through the bottom of the threaded end cap.

## Housing Attachments

1. Temporarily thread the electrode assembly onto the Generator housing, tightening it firmly. Support the entire assembly on the inner core of a large roll of tape as was done in the preceding step 42.
2. Referring to the following Figure 12, fabricate 3 coil support brackets (with the indicated dimensions) from 1/8" thick CPVC sheet.

**NOTE:** For most efficient operation, the coil must be located approximately 1/4" above the tops of the electrodes. A shim is placed between the electrodes and each bracket to achieve correct clearance. Exercise care to avoid cementing shims to the brackets.

3. Use scrap pieces of 1/8" thick CPVC sheet as shims between the tops of the electrodes and the brackets. Apply primer, and then cement, to the brackets and the inside wall of the housing at 120 degree intervals as shown in Figure 11. Attach the brackets and allow cement to air dry for at least 30 minutes before going to step 4.

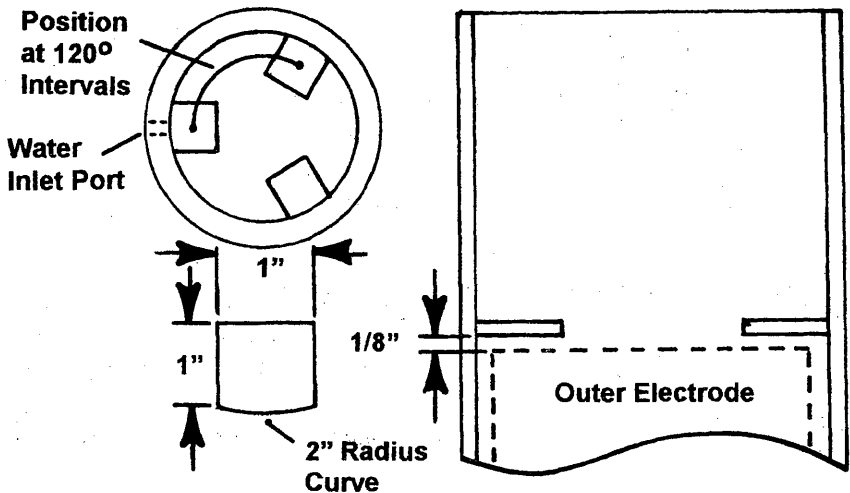

**Coil Mounting Brackets**  
**Figure 12**

4. Remove the electrode assembly from the housing.

**NOTE:** Bracket arrangements for mounting the Generator are dictated by the requirements of each system installation. Figure 13 on page 35

shows one of the simplest and most commonly used arrangements. Other arrangements can be easily constructed with 1/8" CPVC sheet.

**NOTE:** Brackets 1/4" thick are constructed from two layers of 1/8" thick CPVC sheet.

5. Cut four 1-1/2" x 6" mounting bracket strips from 1/8" thick CPVC sheet, as shown in Figure 13 on page 35. Dress the edges of each strip using sandpaper or a fine-tooth file. Form each of the two brackets by applying primer, and then cement, to the mating surfaces of each of two strips and joining them together. Align the edges of each strip and wipe excess cement from the edges.

**NOTE:** Material from a ring cut from the straight coupling will be used to make part of the Generator housing brackets. It will also be used to make a doubler to increase wall thickness of the housing where a hose fitting is installed.

6. Cut a 1-1/2" wide ring from the end of the coupling. Referring to Figure 14 on page 36, and using a band sander, sand the side of the ring to form a flat surface approximately 1-1/4" wide. Sand the side of the ring at another point to form a similar surface. Cut each of two flat surface sections from the ring by cutting at both ends of each flat surface. As shown in Figure 14, this will form two sections from the ring, each with flat outside surfaces 1-1/2" by approximately 1-1/4". Dress the edges of each section and round the corners slightly using sandpaper or a fine-tooth file.

7. As shown in Figure 14, attach a pipe section to each of the two brackets at their midpoints, applying primer to the flat surface of each section and its mating surface on the bracket, and then applying cement. Be sure to square the curved surface of each section with the length of the bracket.

8. Make a doubler by cutting a section 1-1/2" wide from the ring as shown in Figure 14. Dress the edges and round the corners slightly using sandpaper or a fine-tooth file.

Temporarily thread the end cap onto the housing, seating it firmly. Choose a point anywhere around the housing as shown in Figure 14, and mark a spot 1/4" up from the edge of the end cap. Remove the end cap. Apply primer, and then cement, to the mating surfaces of the doubler and housing and attach the doubler to the housing with its lower edge at

the marked spot. Align the edge parallel to the housing bottom edge. Allow the cement to air dry for at least 8 hours before going to step 9.

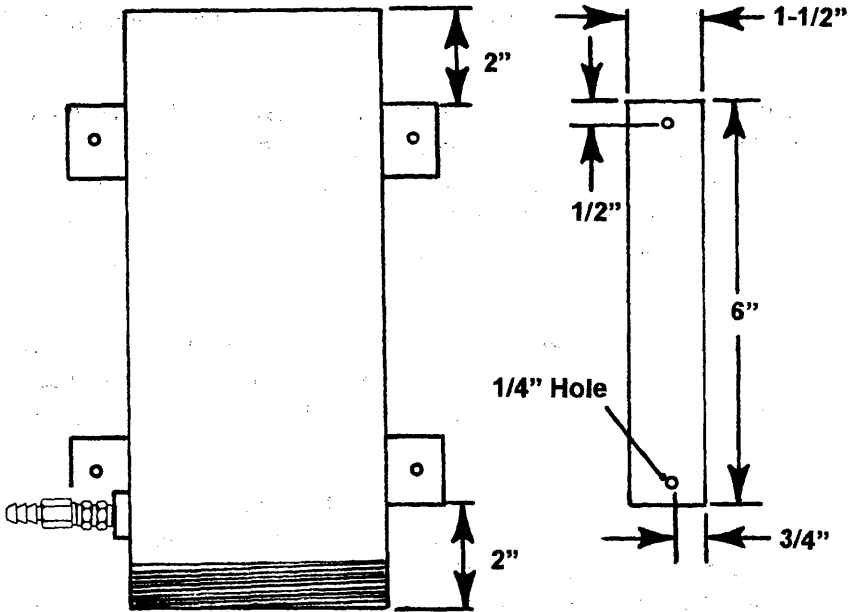

**Housing Attachment Details**  
**Figure 13**

9. Drill a  $3/764$ " hole through the center of the  $1-1/2$ " x  $1-1/2$ " doubler and housing wall as shown in Figure 14. Be sure to keep the hole square with the housing wall.

**NOTE:** Threads will later be tapped into the hole to install a barbed hose fitting to connect to the check valve.

10. Drill a  $1/4$ " fastener hole near the end of each bracket (total of 4 holes) at the locations shown in Figure 13. Slightly round the corners of each bracket using sandpaper or a fine-tooth file.

**NOTE:** The check valve hose attaches to a barbed fitting to be installed later into the hole drilled in step 9. Determine the direction in which you prefer the fitting to point in relation to the mounting brackets. I recommend having the fitting point directly left (as shown in Figure 13) or directly right to minimize Generator space requirements.

11. Position the brackets as shown in Figure 13, and clamp them to a flat surface. Check that the housing seats evenly into the curved section of

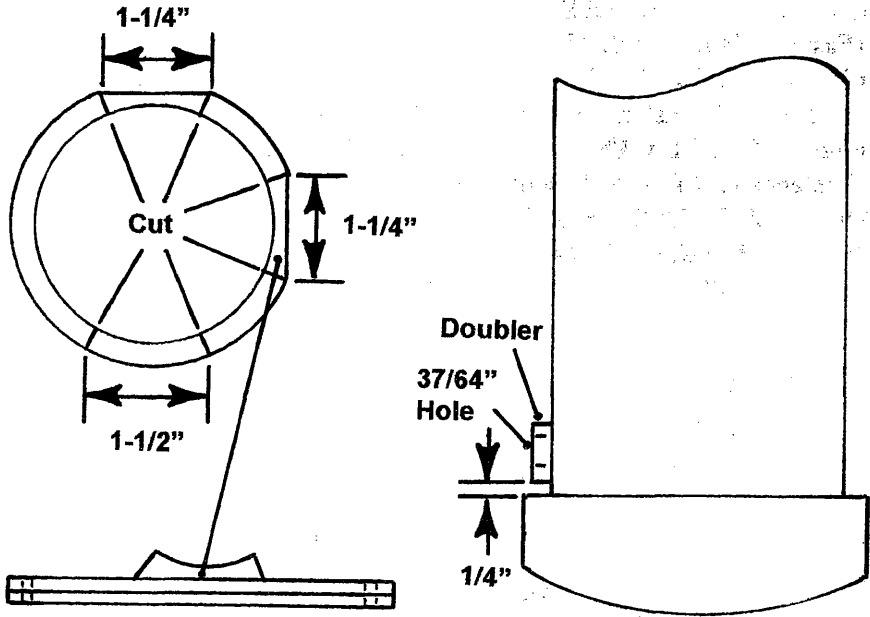

**More Housing Attachment Details  
Figure 14**

each bracket with no gaps between the housing and curved section. If necessary, loosen the clamps to reposition the brackets.

Apply primer, and then cement, to the mating surfaces of the brackets and housing. Attach the housing to the brackets. Place supporting blocks on each side of the housing to keep it from rotating or shifting during assembly. Wait at least 8 hours before loosening the clamps and moving the housing assembly.

## Unthreaded End Cap

### List of Materials:

- Thread taps, 1/8" NPTF and 3/8" NPTF (Cutting Tool Supply: specify Greenfield taps for CPVC pipe, or obtain locally).
- Two 1/8" NPT x 1/8" Barbed Hose Fittings (SMC Part #: 253490).
- Two 3/8" NPT Stainless Steel Inline Check Valves (Generant Part #: ICV-MM-375-SS-1).
- One 3/8" NPT pressure relief valve (Stra-Val Part #: RVA-05, 3/8" NPT, specify pressure setting of 85 psi).

**List of Materials: (continued)**

- One 3/8" NPT Internal Seat Drain Cock  
(Fastener Hut Part #: 230A).
- Five 3/8" PTF x 3/8" Brass Barb Hose Fittings, Male Pipe Rigid  
(PTF Short) (Fastener Hut Part #: 10506B-106A).
- Four 3/8" NPTF x 3/8" Brass Barb Hose Fittings, Female Pipe Rigid  
(Fastener Hut Part #: 10506B-206A).
- One 35 SS Series Stainless Steel Top Mount Level Switch, 1/8" NPT  
(Norgren Part #: 0107-024).
- One LS 11 Plastic Side Mount Level Switch, PBT, 5/8"-11 UNC  
(Norgren Part #: 1873-024).

**Material Source:**

- Cutting Tool Supply (CTS)  
340 W Gerri Ln  
Addison, IL 60101  
Phone: 1-630-543-7171 Fax: 1-630-543-6906
- The Specialty Mfg Co (SMC)  
5858 Centerville Rd  
St Paul, MN 55127  
Phone: 1-651-653-0599 Fax: 1-652-653-0989
- Generant  
1865 Route 23 S, PO Box 768  
Butler, NJ 07405  
Phone: 1-973-838-6500 Fax: 1-973-838-4888
- Stra-Val  
21 Columbus Ave  
Garfield, NJ 07026  
Phone: 1-973-340-9258  
Toll-Free: 1-888-380-966 Fax: 1-973-340-9933
- Fastener Hut Inc  
3781 Glengarry Way NE  
Roswell, GA 30075-2615  
Phone: 1-770-480-4617 Fax: 1-770-998-2721
- Norgren, c/o Kip Fluid Controls Inc  
72 Spring Ln  
Farmington, CT 06032  
Phone, Toll-Free: 1-800-722-5547 Fax: 1-860-677-4999

**NOTE:** A short length of CPVC rod inside the end cap will be used as a spacer for the water level switch.

1. Using a miter box or table saw to assure squareness, cut a spacer approximately 2" long from 1" diameter CPVC rod. Using an "R" size drill bit, drill a hole through the center of the rod its entire length, and parallel to its length. Also drill a hole through the center of the end cap with the "R" drill, as shown in Figure 15.

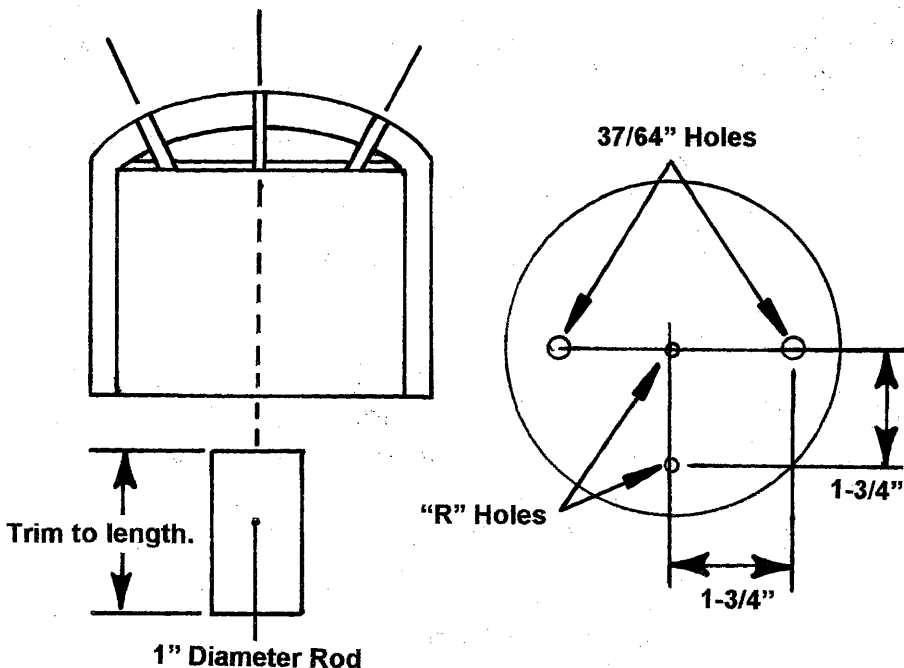

**Unthreaded End Cap Details**  
**Figure 15**

**CAUTION:** BE SURE TO USE ONLY NPTF TAPS. TO PREVENT POSSIBLE WATER AND GAS LEAKAGE, DO NOT USE NPT TAPS. BOTH NPT AND NPTF THREADS WILL SEAL PROPERLY IN NPTF TAPPED HOLES.

**CAUTION:** BE SURE TO TAP TO THE CORRECT DEPTH BY TURNING THE TAP UNTIL THE 12<sup>TH</sup> THREAD FROM THE FRONT OF THE TAP FULLY ENTERS THE HOLE.

**CAUTION:** BE SURE TO ALWAYS KEEP THE TAP ALIGNED PARALLEL TO THE SIDES OF THE SPACER.

2. Using a 1/8-27 tap, tap threads into one end of the hole drilled in the spacer. Be sure to keep the tap aligned parallel to the sides of the spacer and to tap to the correct depth of 12 threads from the end of the tap.

3. Temporarily thread the 35SS water level switch into the tapped hole, seating it firmly. Insert the switch power leads from inside the end cap through the drilled hole. Measure and record the distance from the inside surface of the end cap to the end of the switch center tube.

Remove the switch from the rod. Making a square cut, shorten the rod as required so that the end of the switch center tube is positioned 3" from the surface of the end cap, as shown in Figure 15.

4. Apply primer, and then cement, to the untapped end of the spacer and its mating surface inside the end cap. Install the spacer, being certain to align the holes in the spacer and end cap. Using a cotton swab, remove any excess glue that may have oozed into the hole.

## **Slosh Shield**

1. Using a miter box or table saw to assure squareness, cut a 3-1/16" long section from 1-1/2" CVPC pipe. Drill four (4) 1/8" holes into the sides of the pipe, spaced at 90 degree intervals and 1/4" from the edge as shown in Figure 16 on Page 40.

NOTE: Six of the seven disks cut will be used for the flame arrestor.

2. Using a fly cutter, cut seven (7) 1-57/64" disk from 1/8" thick CPVC sheet. Drill a 3/8" diameter hole through the center of one of the disks.

3. Apply primer, and then cement, to the mating surfaces of the drilled disk and the end of the pipe opposite the four holes. Attach the disk to the pipe, being sure to center the disk on the pipe.

## **Flame Arrestor**

1. Using a miter box or table saw to assure squareness, cut a 3" long section from 1-1/2" CVPC pipe.

2. Using a fly cutter, cut a 1-1/2" disk from 1/8" thick CPVC sheet. Check that the disk fits snugly inside the pipe cut in step 1. If it



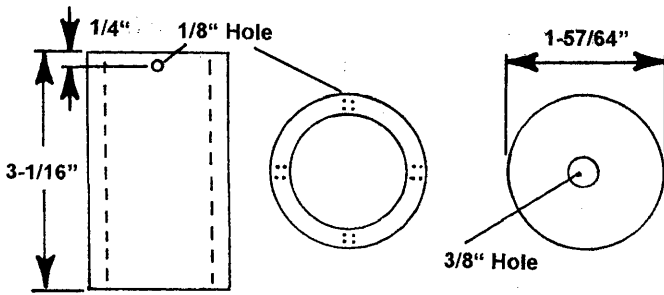

**Slosh Shield Details  
Figure 16**

doesn't fit snugly, adjust the cutter as required and cut a total of four (4) disks.

3. Apply primer, and then cement, to the surface of each of two disks and join the disks together. Align the disk edges and wipe excess glue from the edge of the joined disks. Repeat the procedure for the two remaining disks.

4. In the same manner as in step 3, make 2 stacks of 3 disks each from the six disks cut in step 2 of the Slosh Shield procedure. Allow the disks to air dry for at least an hour and then drill a 37/64" hole through the center of each of the two stacked disks.

5. Referring to the following Figure 17, drill a total of thirteen (13) 1/8" holes through each of the two 1-1/2" disks at the indicated locations.

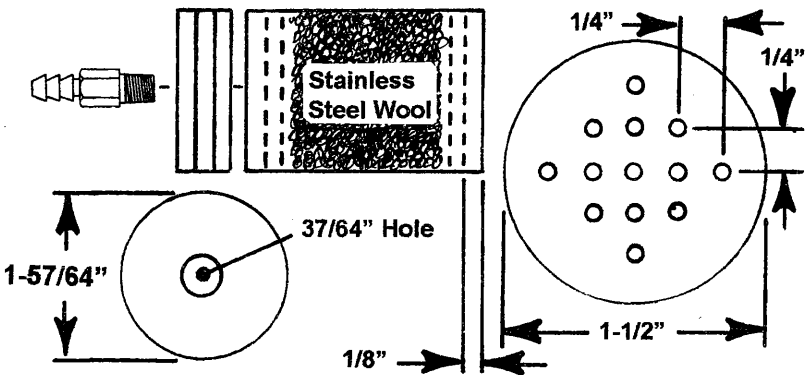

**Flame Arrestor Details  
Figure 17**

6. Apply primer to the edge of one of the 1-1/2" disks and about 3/8" into either end of the 3" pipe bore. Apply cement to the primed surfaces and slide the disk 1/4" into the pipe bore, creating a 1/8" gap between the disk and the pipe end as shown in Figure 17 on page 40. Form a small fillet of cement around the outer junction of the disk and pipe bore. Stand the pipe on end for 5 or 10 minutes (until the cement won't run) to prevent plugging the holes with cement. If any hole is plugged, use a short length of stainless steel rod to open it back up. Allow the cement to air dry for about an hour before going to step 7.

7. Pack the inside of the flash arrestor with coarse stainless steel wool. Repeat the procedure of step 6 to install the remaining 1-1/2" disk.

**NOTE:** Stainless steel wool is available at some large supermarkets, or you can purchase it from the following source:

IWP

2575 W Lemoyne

Melrose Park, IL 60160

Toll Free: 1-800-732-9336

FAX: 1-708-345-0810

**CAUTION:** BE SURE TO USE ONLY NPTF TAPS. TO PREVENT POSSIBLE WATER AND GAS LEAKAGE, DO NOT USE NPT TAPS. BOTH NPT AND NPTF THREADS WILL SEAL PROPERLY IN NPTF TAPPED HOLES.

**CAUTION:** BE SURE TO TAP TO THE CORRECT DEPTH BY TURNING THE TAP UNTIL THE 12<sup>TH</sup> THREAD FROM THE FRONT OF THE TAP FULLY ENTERS THE HOLE.

**CAUTION:** BE SURE TO ALWAYS KEEP THE TAP ALIGNED SQUARELY WITH THE SURFACE AROUND THE DRILLED HOLE.

**NOTE:** Be sure the two stacks of three disks joined in the preceding step 4 have air dried for at least 24 hours.

**NOTE:** When drilling holes in the following step 8, be sure to keep the drill bits squared with the curved outer surface of the unthreaded end cap. This places the axis of each of the three holes at an angle to the axis of the center hole as shown in Figure 15 on page 38.

8. Referring to Figure 15 on page 38, drill two 3/64" holes through the top of the unthreaded end cap, each located 1-3/4" from the center hole in the cap. Be sure to keep the drill bit squared with the curved outer surface of the end cap.

Using an "R" size bit, drill a hole through the top of the end cap 1-3/4" from the center hole in the cap as shown in Figure 15.

**NOTE:** Be sure to keep the taps aligned squarely with the surface around the holes. Tap to the correct depth of 12 threads from the end of each tap.

9. Tap 3/8-18 threads into 3/64" holes at the following locations:

- Two holes on top of unthreaded end cap.
- One hole on bottom of threaded end cap.
- One hole in doubler on housing wall.
- One hole in each of two flame arrestor end caps.

Tap 1/8-27 threads into the "R" size hole closest to the edge on top of the unthreaded end cap.

10. Using a 3/8-18 tap, tap threads into the 3/64" hole in each of the two stacks of three disks joined in the preceding step 4. Apply primer, and then cement, to the mating surfaces of one of the stacks of disks and the 3" flame arrestor pipe. Attach the disks to the pipe, being sure the tapped end of the hole faces outward. Repeat the procedure for the remaining stack of disks.

## **Water Level Switch Test**

**NOTE:** It is important to verify correct operation of the water level switch before installing its slosh shield.

**CAUTION:** NEVER ATTEMPT TO CONTROL POWER TO ANY ELECTRICAL DEVICE DIRECTLY THROUGH THE WATER LEVEL SWITCH. DOING SO WILL DAMAGE OR DESTROY THE SWITCH.

**NOTE:** The water level switch contains very high quality magnetic reed contacts. It will reliably operate through millions of cycles when connected to a properly designed electronic circuit.

**NOTE:** The water level switch is usually supplied with NC (normally closed) contact configuration. Step 1 verifies the NC configuration.

1. Connect ohmmeter leads to the switch power leads. Suspend the switch from its power leads and verify that the ohmmeter indicates closed switch contacts. If the contacts are not closed, go to step 3.

2. Slowly slide the switch float upward. Verify that its contacts open at approximately the midpoint of float travel. If the contacts open properly, go to step 4. If the contacts do not open properly, the switch is defective and must be replaced.

3. Using a marking pen, mark a small dot on top of the switch float.

**NOTE:** The switch probably has NO (normally open) contact configuration. Inverting the float changes it to the required NC configuration.

Carefully remove the float retaining clip located at the bottom of the center tube. Remove the float, invert it and reinstall. Reinstall the retaining clip. Verify that the dot on the float is now at the bottom and repeat the procedure of the preceding steps 1 and 2.

4. Using a countersink tool, or large drill bit, form a small bevel in the outer end of the center hole in the unthreaded end cap through which the switch leads pass.

**NOTE:** As an added precaution against possible water and/or gas leakage, I recommend using pipe joint compound on all threaded Generator housing components.

**CAUTION:** DO NOT APPLY EXCESSIVE TORQUE TO THE WATER LEVEL SWITCH THREADS WHILE INSTALLING THE SWITCH INTO ITS MOUNTING SPACER. EXCESSIVE TORQUE CAN DAMAGE THE SPACER THREADS, CAUSING WATER AND/OR GAS LEAKAGE, AND POSSIBLE SYSTEM FAILURE.

5. Apply a light coating of pipe joint compound to the threads of the switch and mounting spacer according to directions on the product label. Insert the switch power leads through the spacer hole and thread the switch into place, seating it firmly.

**NOTE:** The following steps are use to verify correct switch operation in response to water level changes.

6. Obtain a transparent container (such as a large glass jar) with an outside diameter of approximately 2-1/2" to 3-3/4" and inside depth of at least 3-1/2".

Place the unthreaded end cap on top of the container with the switch inside. Be sure the bottom surface of the end cap seats evenly on top of the container. Position the end cap so that at least one of the large tapped holes projects inside the container and the switch float is at least 1/4" away from the container wall.

**NOTE:** Measure water level with the switch float in water.

7. Connect the ohmmeter leads to the switch leads. Check that the switch contacts are closed. Very slowly pour water through the large tapped hole until the switch contacts just open, and remain open. If the contacts close again, add a slight amount of water and wait several seconds before checking again. Keep repeating this process until the switch remains open. Check that the water level is at least 2" from the top edge of the jar. If the water level is less than 2" from the top, the switch is defective and must be replaced.

8. Remove the end cap assembly from the jar and dry as necessary with a soft clean cloth.

9. Apply primer, and then cement, to the mating surfaces of the slosh shield and end cap. Attach the slosh shield, centering it around the switch float.

## **Toroid Coil**

### **List of Materials:**

- One Ferrite Toroid Coil Core, 3.50 OD x 2.00 ID x .500 Thick (National Magnetics Part #: 995).
- Copper Magnet Wire, Teflon coated, Heavy Build, 23 AWG, 550 Ft (MWS Wire Industries, must be custom ordered)
- Teflon Etching Solution ("FluoroEtch") (Acton Technologies)
- One Package Heat Shrink Tubing, Assorted Sizes (Radio Shack, Catalog #: 278-1610).

## Material Sources:

**National Magnetics Group**  
1210 Win Dr  
Bethlehem, PA 18017-7061  
Phone: 1-610-867-7600  
FAX: 1-610-867-0200

**MWS Wire Industries**  
31200 Cedar Valley Dr  
Westlake Village, CA 91362  
Phone: 1-818-991-8553  
Fax: 1-818-706-0911

**Acton Technologies**  
100 Thompson St  
PO Box 726  
Pittston, PA 18640  
Phone: 1-570-654-0612  
Fax: 1-570-654-2810

**Radio Shack**  
(Nationwide stores)

**NOTE:** The HydroStar coil is hand-wound around a ferrite toroid core with insulated, high temperature copper wire. Close attention to detail and craftsmanship is essential to building an efficient and reliable coil. There are literally millions of different coil configurations in existence. It's a great area for experimenting since coil design is as much art as it is science. Believe it or don't, there's actually an organization dedicated to the craft, the International Coil Winding Association, based in England.

**NOTE:** Be forewarned that winding any coil, especially a toroid coil, is a tedious affair; but I'll do my best to make the job as easy as possible. The coil is created from 2,000 turns of insulated copper wire wrapped around a circular magnetically sensitive core. That means you have to drag each wire wrap through the toroid core just as many times.

**NOTE:** Teflon insulated copper magnet wire is the only way to go. It handles heat extremes very well and is impervious to just about anything you can throw at it. It isn't cheap, but well worth the investment.

Custom order it from MWS Wire Industries. They carry over 25,000 different magnet and specialty application wires. Be sure to order "Double Build" (extra heavy) insulation, 23 AWG. You'll need about 500 to 550 feet, so it's probably best to order 550 feet.

After the coil is completed, it should be coated with a few thin layers of CPVC cement. That way you end up with something that will last forever, is practically bombproof, and is easy to solidly attach inside the housing with CPVC cement. But, getting anything to stick to Teflon takes special chemical etching (that's why Teflon cookware is so popular). It's commercially done by etching with some pretty nasty stuff. Several companies specialize in the process, but you don't want to know the cost. A safe and easy etching process that can be done at home, yet gives great results, has recently been developed using a product called FluoroEtch. You simply warm FluoroEtch to about 130 degrees, slosh the coil around in it for about a minute, slosh in isopropyl or methyl alcohol (sadly, the kinds you can't drink) for a minute or so, wash in warm soapy water, rinse with warm water, and let air dry. After doing that, just about anything will stick to the Teflon coated coil wire. I'm telling you all this so that when you call the nice folks at Acton Technologies you'll sound knowledgeable enough that they won't hesitate selling you FluoroEtch.

1. I recommend cutting the magnet wire into four (4) 100' lengths and one (1) 150' length. Otherwise, you have to drag 550' of wire through the core 2,000 times. Using math, that works out to just over 104 miles of wire dragging (averaged over 550 feet), or one sore arm and a tangled mess! By working with 100' and 150' lengths, you have to make four solder splices to the wire, but you cut your wire dragging down to less than 22 miles. You could even go with eleven (11) 50' lengths; cutting it to 9-1/2 miles and 10 solder splices. Or, carried to the extreme, 550 one foot lengths cuts it to less than 1/4 mile (1,001 feet), but you have to make 549 solder splices!

Don't try short-cutting things by wrapping the wire around the core several times and pulling the rest of the wire on through. The continual bending and straightening will destroy the wire long before you reach its end. A modified version of that method works, but takes a fair amount of skill and experience to master (or requires special equipment).

Forming a 3.5" OD x 2" ID x .50" toroid coil from 23 AWG wire

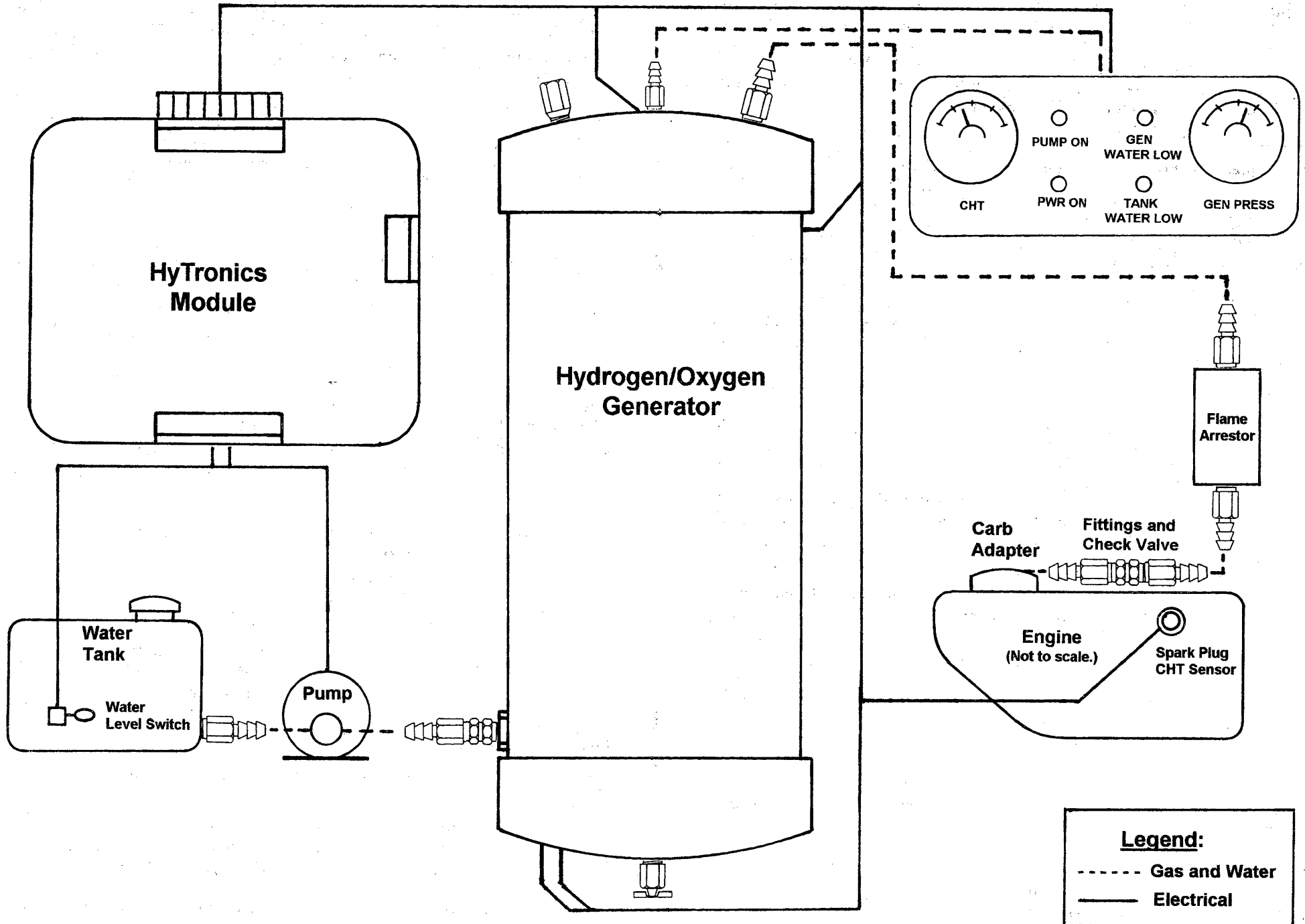

***The Incredible HydroStar System!***

**Figure 18**



requires about 250 turns of wire per wrapped layer. Since the coil builds in size as it's wrapped, each wrap uses an average of about 3" of wire. So, each 100' wire provides about 400 wraps, or slightly over 1-1/2 layers. Therefore, four (4) 100 foot lengths and one (1) 150 foot length will build an 8 layer coil of at least 2,000 turns.

**NOTE:** Save the 150' wire for the last layer in case you need extra wire to complete the 8th layer without splicing near the coil entry wire. Any time you interrupt wrapping, be sure to tightly wrap a strip of plastic electrical tape completely around the coil to secure the last wrap. Teflon is extremely slippery stuff; you don't want to come back only to find that all your coil wraps are loose. It will happen if you don't use tape!

**NOTE:** The first complete wrapping of the entire coil diameter forms layer #1 for the inner core. This is the only critical layer since each subsequent layer will automatically position itself by nesting between the wires of the previous wrap.

2. Referring to Figure 19 on page 50, slip a 1" length of small heat shrink tubing about 4" onto the magnet wire and apply heat to shrink it in place. If you are right-handed, you'll probably choose to wrap the coil in a clockwise direction, holding the core with your left hand. In that case, lay the shrink tubing on top of the core, angled off to the left at about 30 degrees from straight out as shown. Start the first wire wrap over the tubing at about its midpoint. This will be the start of layer #1 for the inner core. Be sure to keep the wire wraps tight against each other on the inside edge of the core, with no overlapping. Keep tension on the wire, with the wire always pointing straight out from the core. Precise wire positioning has little to no effect on overall coil performance. But, the first wrap dictates the wire positions of each subsequent wrap since each wire will fall into the depression formed between the two wires of the preceding wrap. In short, if you do a sloppy job on the first layer, you'll end up with a sloppy coil. So, take your time to do the job right. Continue wrapping until you have completed a full turn (completing coil inner layer #1). Tightly wrap a strip of plastic electrical tape around the wire and the coil entry wire at the end of layer #1.

3. Check the position of each wire on the outside edge of the core. If wrapped perfectly (which, of course, is impossible) there will be a .019" gap between any two wires. But, you can position each wire close

enough by using a short piece of coil wire as a feeler gauge. If the feeler gauge wire touches the core surface between any two wires, the gap is too wide, so at least one of the wires is out of position. Using your fingernail, or other blunt-ended instrument that won't damage the wires, slightly shift wires to close the gap enough to keep the feeler gauge from contacting the core surface. Any gap that is too wide indicates an adjacent gap is too narrow, so those wires should be moved further apart. After going around the coil a few times, you will also be able to visually detect wires out of position.

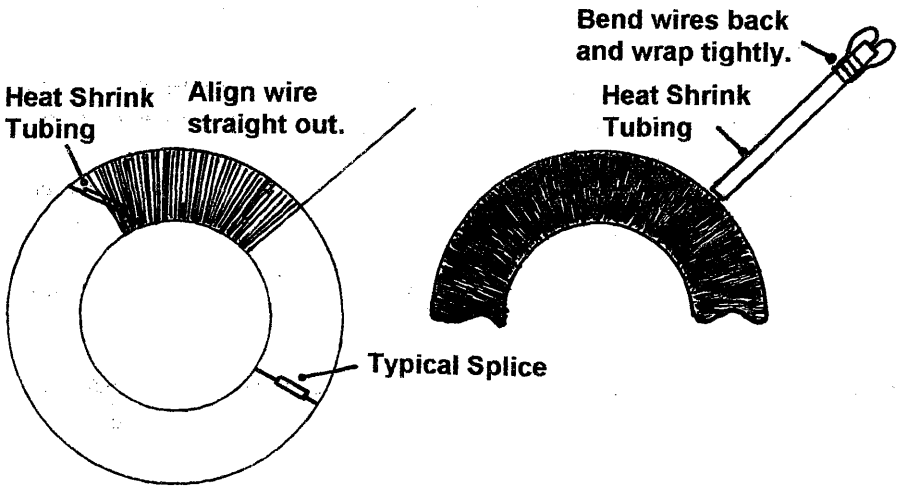

**Toroid Coil Details  
Figure 19**

4. Mix about a 1/2-ounce batch of epoxy (such as J-B WELD). Using a small brush, carefully apply a thin layer of epoxy around the outer edge of the coil. Apply with a motion parallel to the wires to prevent wire movement, being sure the epoxy contacts the coil surface between wires. Suspend the coil from its wires and allow the epoxy to cure for at least 8 hours before going to step 5.

**NOTE:** While wrapping coil layer #2, be sure to count and record the number of turns.

5. Start wrapping coil layer #2, exercising care to position each wire into the gap formed between the wires of layer #1 on the inner and outer edges of the coil. Count and record the number of turns.

Continue wrapping until you get within about one foot of the wire end. Secure the wire by tightly wrapping plastic electrical tape around the wire and coil.

**NOTE:** Coil thickness tapers down between the inner and outer edges. To minimize inner coil thickness, position wire splices on the top or bottom of the coil, midway between the edges as shown in Figure 19 on page 50.

6. Temporarily wrap the wire for two or three more turns and cut it about 1/2" short of the outer edge. To splice to the next wire length, unwrap the wire and use a sharp knife to scrape the Teflon coating from about 1/2" of each wire end. Always keep the knife blade perpendicular to the wire to prevent damage.

7. Slide a 1/2" length of heat shrink tubing over the end of the next length of coil wire. Be sure the tubing is large enough to fit over a wire splice. Twist the wire ends together for 7 or 8 turns to form a splice. Cut the splice to a length of about 1/4" and bend it back toward the coil until it lays flush against the coil wire. Solder the splice, slide the shrink tubing until it's centered over the splice, and apply heat to shrink the tubing. Wait a minute or two for the tubing and splice to cool and go on to step 8.

8. Remove the electrical tape from the coil and continue wrapping until layer #2 is completed. Record the total number of turns required to complete layer #2.

**NOTE:** Although the total number of coil turns is not critical, almost all coils require a total of 8 wire layers.

9. Referring to the recorded number of coil turns needed to complete layer #2, determine the number of coil layers required to complete the coil with a total number of 1,800 to 2,100 turns.

**NOTE:** Be sure to end the last coil layer near the beginning of layer #1. Do not finish the coil with a partial last layer.

10. Repeat the procedure of the preceding steps 5 through 7 until the last layer has been completed. Be sure the last turn ends within a turn or two of the coil entry wire. Cut the last wire to a length of about 12".

**NOTE:** Do not shrink the heat shrink tubing in the following step 11. It will be used only temporarily to secure the coil wires.

11. Referring to Figure 19 on page 50, temporarily slide a 5" length of heat shrink tubing over the ends of the coil wires. Draw the tubing snugly up against the outer coil edge and bend the coil leads back toward the coil at the outer end of the tubing. Tightly wrap each coil wire 4 to 5 turns around the tubing about 1" from the end, and twist the wires together for at least 5 or 6 turns.

**CAUTION: EXERCISE EXTREME CARE TO PREVENT DAMAGING THE COIL WIRES DURING THE FOLLOWING PROCEDURES.**

**CAUTION: TO ASSURE PROPER BONDING OF CPVC CEMENT TO THE COIL AFTER ETCHING, DO NOT HANDLE THE COIL WITH BARE HANDS. IF THE COIL MUST BE HANDLED, WEAR CLEAN COTTON GLOVES.**

12. Using FluoroEtch, while suspending the coil by the heat shrink tubing, etch the surfaces of the Teflon coated coil wires. Closely follow the directions on the product label. If necessary as an aid to etching, refer to the general description of the etching procedure called out in the second paragraph on page 46. Always handle the coil by suspending it from the tubing during each phase, from etching through final warm water rinse. Use clean paper towels to absorb water drips from the bottom of the coil until dripping ceases. Allow the coil to air dry for at least 4 to 5 hours before going to step 13.

13. Using a soft bristle brush, coat the entire surface of the coil with a thin and even layer of CPVC cement. Use cotton swabs to wipe away excess cement that may be dripping from the bottom of the coil until dripping ceases. Allow the cement to air dry for at least an hour and then apply a second thin and even layer of CPVC cement in the same manner.

14. Repeat the procedure of the preceding step 13 until a total of 5 or 6 layers of CPVC cement have been applied to the coil, allowing at least one hour drying time between each layer. Allow the final layer of cement to air dry for at least 8 hours before going to step 15.

**CAUTION: EXERCISE CARE NOT TO PULL THE COIL EXIT WIRE AWAY FROM THE COIL WHILE REMOVING THE HEAT SHRINK TUBING.**

15. Unwrap the coil wires from the heat shrink tubing and remove the tubing from the wires. Cut a 1" length of heat shrink tubing large enough to slip snugly over the coil wires and the shrink tubing of the coil entry wire. Draw the tubing tightly up against the coil outer edge and apply heat to shrink the tubing.

16. Using a soft bristle brush, apply a thin bead of CPVC cement about 1/4" wide around the coil end of the tubing and surface of the outer coil edge. Allow the cement to air dry for about an hour and then apply a second bead of cement over the first bead.

17. Suspend the coil from the end of its wires and allow it to air dry for at least 24 hours before going to step 18.

18. Cut the coil wires to a length of 3" from the coil.

## **Toroid Coil Installation**

**NOTE:** I recommend locating the coil electrical connections on the side of the housing directly opposite the water pump inlet port. This location minimizes possible coil wire connector fatigue due to the effects of water turbulence at high pump pressure.

1. Using a #41 drill bit, drill two holes in the housing wall at the locations shown in Figure 20.

2. Cut two (2) 4" lengths of 3/32" bare stainless steel welding rod. Create a 90 degree bend in one end of each rod to form a leg approximately 1-1/2" inches long, as shown in Figure 20 on page 54. Cut the other leg to a length of 3/4". Using a file, square off the ends of each rod and deburr the edges.

3. Use a sharp knife to scrape the Teflon coating from about 1/2" of each coil wire end. Always keep the knife blade perpendicular to the wire to prevent damage.

4. Wrap each coil wire end around the top of a 1-1/2" rod leg for at least 4 or 5 turns. Using silver bearing electrical solder, solder each wire to its rod leg. Trim away any excess wire. Form a wire strain relief at the leg bottom by wrapping heavy thread at least 2 or 3 turns around the leg and wire. Secure the thread with a knot placed on the outside of the rod bend.

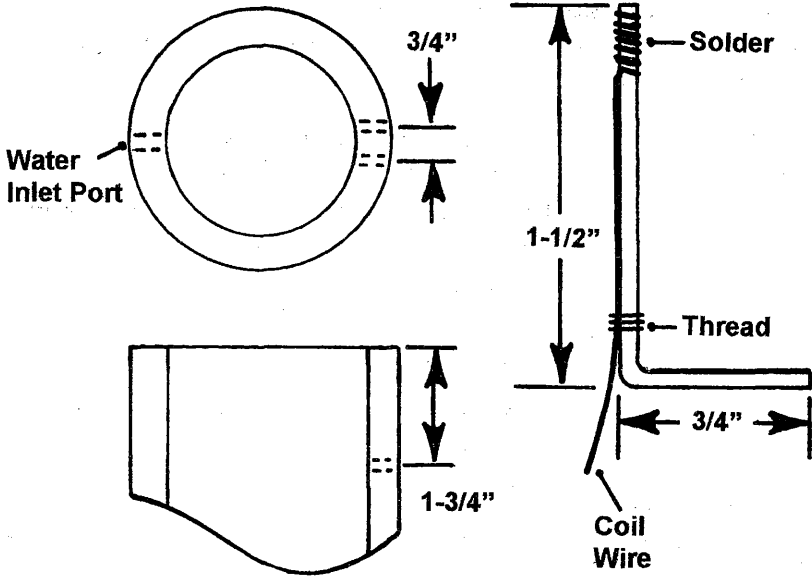

**Toroid Coil Installation  
Figure 20**

5. Using a soft bristle brush and warm soapy water, clean the soldered areas of the rod and wire. Rinse with warm water and allow the thread to air dry for at least an hour before going to step 6.
6. Coat the entire length of the long rod leg with a thin even layer of CPVC cement. Allow the cement to dry for about 15 minutes and apply a second thin coat of CPVC cement. Allow the cement to air dry for about 15 minutes before going to step 7.
7. Temporarily install the coil on top of its three support brackets within the housing. Position the coil with the wires and rods pointing toward the holes drilled in the preceding step 1. Temporarily attach three small strips of electrical tape on top of the coil to mark the location of each support bracket.
8. Remove the coil from the housing and apply primer to the bottom of the coil at the three marked locations and the top surface of all three support brackets. Coat the top of each support bracket with a heavy layer of CPVC cement. Install the coil onto the support brackets,

positioning it with the wires and rods pointing toward the two #41 drilled holes. If necessary, shift the coil slightly to center its outside edges within the housing. Allow the cemented rods and wires to air dry at least an hour before going to step 9.

**NOTE:** The two #41 holes in the inside housing wall must be countersunk to a depth sufficient to clear the radius of the inside bend of each rod, allowing the soldered leg of each rod to lay flush against the housing wall with the soldered leg pointing upward.

9. Remove the three tape strips from the top of the coil. Using a countersink tool or large drill bit, deburr the inside ends of the #41 holes. Insert the rod ends into the holes and check that the inside bend radius clears the edge of each hole. If not, countersink slightly deeper until the desired clearance is obtained.

10. Using #400 grit or finer sandpaper, polish the surface of the unsoldered leg of each rod. Mix a small quantity of epoxy such as J-B WELD. Apply a thin coat of epoxy to the unsoldered leg of each rod. Using a toothpick, or other precise tool, apply a thin coat of epoxy to the inside of each #41 hole.

11. Apply a heavy layer of CPVC cement to the soldered leg of one rod. Fully insert the rod into the #41 hole with the soldered leg pointing directly upward. Hold the rod in place for about 5 minutes until the cement dries sufficiently to hold it in place. While waiting for the cement to partially dry, clean epoxy from the rod end using a soft clean cloth and solvent such as MEK or acetone. Repeat this procedure for the remaining rod. Allow the epoxy to cure for about 8 hours before going to step 12.

**NOTE:** Several layers of CPVC cement are used to secure the coil to the housing brackets, rods and wires to the housing wall, and to seal the rods against possible gas and/or water leakage through the holes in the housing.

12. Arrange the coil wires so they contact the housing wall as much as possible. Lay the housing on its side and apply a thick layer of CPVC cement over the wires and soldered leg of each rod. Extend the cement layer around the hole where each rod enters the housing wall, forming about a 1/2" diameter puddle around each hole. Allow the cement to air dry for at least 15 minutes before going to step 13.

13. Stand the housing on end. Using a soft bristle brush, apply a thick layer of CPVC cement over and around the coil surface above where it contacts each of the three support brackets. Be sure the layer extends the width of each bracket. Allow the cement to air dry for at least 15 minutes before going to step 14.

14. Repeat the procedure of the preceding steps 12 and 13 at least 4 or 5 times to obtain the desired thick layer of cement. Allow the cement to air dry for at least an hour between successive layers.

15. After the epoxy has cured for at least 24 hours, use #400 grit or finer sandpaper to remove epoxy residue from the rod ends.

## **Unthreaded End Cap Installation**

**NOTE:** Generator function and efficiency is not effected in any way by the rotational position of the unthreaded end cap.

1. Check that the mating surfaces of the end cap and top of the housing are clean and free of debris of any kind. Clean the mating surfaces if necessary using a soft clean cloth and mild solvent such as isopropyl alcohol.

2. After determining the desired position of the end cap, apply primer to the mating surfaces of the end cap and top of the Generator housing. Apply a thin layer of CVPC cement to the primed areas and slide the parts together, seating them firmly.

3. Stand the housing on end to prevent the possibility of excess cement running into threaded holes in the end cap, allowing it to remain in that position for at least an hour while the cement air dries.

## **Generator Final Assembly**

1. Cut the two rod ends protruding through the bottom of the threaded end cap to a length of 1/2". Using a file, square the end of each rod and deburr the edges.

**NOTE:** As an added precaution against possible water and/or gas leakage, I recommend using pipe joint compound on all threaded Generator housing components.



**CAUTION: TO PREVENT DAMAGE TO THREADED HOLES IN CPVC MATERIAL, DO NOT APPLY EXCESSIVE TORQUE TO COMPONENTS WHILE INSTALLING. THREAD DAMAGE CAN CAUSE WATER AND/OR GAS LEAKAGE, AND POSSIBLE SYSTEM FAILURE.**

5. Apply a light coating of pipe joint compound to all threaded holes in the Generator housing and end caps according to directions on the product label.

6. Apply a light coating of pipe joint compound to the threads of the drain cock. Thread the drain cock into the 3/4" threaded hole in the bottom of the threaded end cap, seating it firmly. Repeat this procedure to install the remaining components:

- One 3/8" Barbed Hose Fitting into 3/4" hole in housing doubler.
- One 3/8" Barbed Hose Fitting into 3/4" hole on top of housing.
- One 1/8" Barbed Hose Fitting into "R" size hole on top of housing.
- One Pressure Relief Valve into 3/4" hole on top of housing.

7. Using a toothpick, or similar precise tool, force a small quantity of Silicone Sealant (RTV Cement) into the hole in the end cap through which the water level switch leads pass. Form a small and smooth fillet of sealant around the leads and end of the hole. Allow the sealant to cure for at least 24 hours before going to step 8.

8. Visually inspect all surfaces and components of the housing and end cap to verify their integrity. Correct possible defects as required.

9. Thoroughly flush the interior of the Generator housing with warm tap water. Stand the housing on end and allow excess water to drain for at least 15 minutes. Using a soft clean cloth, dry the housing exterior and threads of the housing and end cap.

10. Apply a light coating of pipe joint compound to the housing and end cap threads. Thread the end cap onto the housing and tighten firmly.

## **In-Dash Indicator Panel Assembly**

**NOTE: Personal preference dictates the layout of panel gauges and LED indicators. During assembly, refer to Figures 5, 6, and 7 on pages 13, 15, and 17 respectively.**

### List of Materials:

- One Cylinder Head Temperature (CHT) Gauge Kit, 2-1/16" Diameter, (includes spark plug mounted thermocouple sensor) (Bus Boys Part #: VDO-310901).
- One 2-Gauge Custom Console (Bus Boys Part #: VDO-1108720).
- One Pressure Gauge, 2-1/16" Diameter (Auto Meter Products Model #: 2360).
- Two Bulb and Socket Sets, 2 Watt (Auto Meter Products Model #: 2357)
- Four LED Indicators:
  - Two Green (Radio Shack Part #: 276-304).
  - One Yellow (Radio Shack Part #: 276-351).
  - One Red, Blinking (Radio Shack Part #: 276-308).
- Three 55' Spools 18 Gauge Insulated, Stranded Hookup Wire (Radio Shack Part #: 278-1220).
- One 9-Position Male Interlocking Connector (Radio Shack Part #: 274-229).
- One 9-Position Female Interlocking Connector (Radio Shack Part #: 274-239).
- Two Packages Crimp-On Snap Connectors (Each: 5 male, 5 female) Radio Shack Part #: 64-3085 and 64-3086).
- One Package Assorted Ring Terminals (Radio Shack Part #: 64-3032).
- One Package Assorted Grommets (Radio Shack Part #: 64-3025).
- One 10' length 1/8" Silicone Braid Reinforced Tubing (US Plastic Stock #: 54051).
- Twenty (20) Small Stainless Steel Worm Thread Hose Clamps (Local Hardware).
- One Package Small Nylon Tie-Wraps (Local Hardware).

### Material Sources:

Bus Boys, Inc  
183 Lake Blvd East  
Redding, CA 96003  
Phone: 1-530-244-1616 Fax (7/24): 1-530-224-0933

Auto Meter Products Inc  
413 W Elm St  
Sycamore, IL 60178  
Phone: 1-815-895-8141 Fax: 1-815-895-6786

United States Plastic Corp (see page 22 for ordering details).

**Radio Shack**  
(Nationwide stores)

**NOTE:** The quickest and easiest, and usually the most attractive, method for mounting gauges and LED's is to use a prefabricated console attached to the top of the dash panel. Other methods may work just as well, but I'm recommending the VDO-1108720 Custom Console, which is molded from ABS plastic and is both attractive and durable.

1. Temporarily mount the CHT and pressure gauges in the console. Referring to Figure 2 on page 10, determine the best locations for the 4 LED's and place reference marks at those locations on the outside of the console. Drill a 7/32" hole at each location. To assure proper adhesion of silicone sealant to the console interior surface, roughen the surface immediately around the area of the drilled holes with sandpaper.

2. Temporarily disconnect the CHT gauge thermocouple lead and mount the gauge in the console. Apply a light coating of pipe joint compound to the 1/8-27 threads of the pressure gauge and 1/8-27 barbed hose fitting. Thread the fitting into the gauge and tighten firmly. Slip the 1/8" silicone tubing fully onto the barbed fitting and secure with two small stainless steel hose clamps. Firmly tighten the hose clamps and mount the pressure gauge in the console.

**NOTE:** The sorter of the two LED leads is always the anode (+) lead.

3. Identify the anode (+) lead of each LED and cut to a length of 1". Cut four (4) 3-foot lengths of 18 gauge hookup wire and strip 1/2" of insulation from the end of each wire. Wrap the stripped end of each wire end around each anode lead and solder. Slide a 1-1/2" length of heat shrink tubing over each wire and flush against the LED and shrink the tubing.

4. Referring to Figure 2 on page 10, identify the console location for each LED. Using masking tape, or other means of labeling, attach an identifying label to each anode wire.

- Green, PWR ON
- Green, PUMP ON
- Yellow, GEN WATER LOW
- Blinking Red, TANK WATER LOW

5. Cut two lengths of hookup wire to use as jumper wires between the bulbs and sockets for the gauges. Strip 1/2" of insulation from the ends of each wire. Solder a wire to one socket center connector. Slide a 1" length of heat shrink tubing onto the wire and as far as possible onto the socket base. Shrink the tubing. Cut a 3-foot length of hookup wire and strip 1/2" of insulation from one end. Twist the ends of the soldered jumper wire and 3-foot wire together. Slide a 1" length of heat shrink tubing onto the wires, and solder the wires to the other socket center connector. Slide the tubing as far as possible onto the socket base and shrink the tubing. Label the wire "Positive" (+).

6. Cut a 6" length of hookup wire. Repeat the procedure of step 5 to connect the 6" wire and jumper wire between the two socket base connectors. Strip 1/2" of insulation from the end of the 6" wire.

7. Cut the cathode lead of the green "PWR ON" LED to 1-1/2" long. Cut the cathode lead of the yellow "GEN WATER LOW" LED to 1" long. Cut an appropriate length of hookup wire to serve as a jumper wire between the cathodes of both LED's. Strip 1/2" of insulation from each end of the wire. Solder the jumper wire to the yellow LED cathode. Slide a 1-1/2" length of heat shrink tubing over the wire and flush against the LED and shrink the tubing.

Twist the stripped ends of the jumper wire and 6" wire of step 6 together. Slide a 1" length of tubing over the two wires and solder them to the green LED cathode. Slide the tubing flush against the LED and shrink the tubing. Cut a 3-foot length of hookup wire and strip 1/2" of insulation from one end. Solder the wire to the green LED cathode. Slide a 1- 1/2" length of heat shrink tubing over the wire and as far as possible onto the LED lead and shrink the tubing. Label the wire as "Ground."

Cut the cathode leads of the two remaining LED's to 1" long. Cut two (2) 3-foot lengths of hookup wire and strip 1/2" of insulation from the end of each wire. Solder the wires to the LED cathodes. Slide a 1-1/2" length of heat shrink tubing over each wire and flush against the LED and shrink the tubing. Label the green LED wire as "PUMP ON CATHODE" and the red LED wire as "TANK WATER LOW CATHODE."

**NOTE:** Silicone sealant cures by chemical reaction with oxygen and water moisture in the air, which is why it's sometimes referred to as RTV (Room Temperature Vulcanizing) cement. Sealant cure time

can be shortened considerably by placing a water-dampened cloth within the console interior and placing the console into a plastic grocery bag (don't seal the bag so that it's airtight). This method is especially effective in dry climates.

8. Slide each LED into its correct mounting hole on the console. Slide one LED about 1/16" back from the interior surface of the console and apply a small amount of silicone sealant into the gap between the LED flange and the console surface. Slide the LED back into place and flush with the console surface. Apply a thick bead of sealant around the LED flange and about 1/4" onto the console surface. Repeat the same procedure for the three remaining LED's. Allow the sealant to cure for at least 24 hours before going on to step 9.

9. Install the bulbs and sockets into the gauges. Draw the seven LED wires and bulb socket wire together a short distance from the LED's and secure the wire bundle with a tie-wrap. Tighten the tie-wrap and cut off its unused strap.

10. Drill and/or grind a hole to install a 5/8" ID grommet through the engine compartment firewall at an appropriate location for routing of HyTronics wires, thermocouple lead, and pressure gauge tube. Deburr the hole and install a 5/8" ID grommet. Insert the thermocouple lead through the grommet from the engine compartment side and reattach it to its CHT gauge terminal.

11. Permanently attach the console to the dash at the desired location. Secure the wires, thermocouple lead, and CHT tube bundle with a tie-wrap placed about every 6" along the length of the bundle. To prevent collapsing the pressure gauge tube, be sure not to over-tighten the tie-wraps.

12. Cut the ends of the eight wires to the same length and strip 1/4" of insulation from the end of each wire. Attach each wire to a separate pin of the 9-Position Male Interlocking connector by crimping or soldering.

13. Remove a spark plug from the engine and plug the hole with a soft clean cloth. To assure good electrical contact for the thermocouple, polish the area contacted by the spark plug with #400 grit or finer sandpaper. Remove the cloth from the spark plug hole. Slip the thermocouple ring over the spark plug threads and reinstall the spark plug. Tighten the spark plug to its normal torque value.

# Water Tank and Pump

## List of Materials:

- One Rectangular Polyethylene Tank, 16 Gallon, 21" x 14" x 14"  
(US Plastic Part #: 8658).
- High-Low Temperature Silicone Tubing, 3/8" ID, 20'  
(US Plastic Stock #: 54037).
- Silicone Braid Reinforced Tubing, 3/8" ID, 20'  
(US Plastic Stock #: 54055).
- One High-Head Pump, 12 vdc, 75 psi (minimum) (Flojet)
- One Brass Bushing, 3/4" PTF Male x 3/8" PTF Female  
(Fastener Hut Part #: 3220X12X06A).
- One Package Crimp-On Butt Connectors  
(Radio Shack Part #: 64-3037).

## Material Sources:

Radio Shack (Nationwide stores).

Fastener Hut Inc (see page 37 for ordering information).

United States Plastic Corp (see page 22 for ordering information).

Flojet Corporation

20 Icon

Foothill Ranch, CA 92610

Phone: 1-949-859-4945

Toll-Free: 1-800-235-6538

Fax: 1-949-859-1153

**NOTE:** Water tank capacity is not critical, but should be at least 5 - 10 gallons. The recommended tank is sturdily constructed, holds 16 gallons, and is furnished with a 3/4" FPT outlet fitting.

1. Apply a thin film of pipe joint compound to the internal threads of the 3/4" x 3/8" bushing and threads of a 3/8" barbed hose fitting. Thread the fitting into the bushing and tighten firmly.

2. Apply a thin film of pipe joint compound to the external threads of the bushing and internal threads of the water tank fitting. Thread the bushing into the tank and tighten firmly.

**NOTE:** The water level switch can be installed at the midpoint of either side wall of the tank. Determine the desired location based on routing of

electrical leads, trunk layout, etc. One switch lead will be grounded to the vehicle frame in the trunk area and the other lead will be connected to the HyTronics module.

3. Drill or cut a 5/8" hole in the side wall of the water tank at the midpoint of its length and 4" up from the bottom. Flush the tank with tap water to remove plastic shavings.

4. Remove the tank cap. Drill a 3/16" hole through the center of the cap and thread with a 3/8-18 tap. Flush the cap with tap water to remove plastic shavings. Thread a 3/8" barbed hose fitting into the tapped hole and seat firmly. Cut a 6" length of high-low temperature silicone tubing. Slip the tubing onto the fitting and secure with two stainless steel hose clamps. Tighten the clamps firmly.

**CAUTION:** NEVER ATTEMPT TO CONTROL POWER TO ANY ELECTRICAL DEVICE DIRECTLY THROUGH THE WATER LEVEL SWITCH. DOING SO WILL DAMAGE OR DESTROY THE SWITCH.

**NOTE:** The water level switch contains very high quality magnetic reed contacts. It will reliably operate through millions of cycles when connected to an LED.

5. Strip 1/4" of insulation from the ends of the water level switch leads. Connect ohmmeter leads to the switch leads. Pivot the switch float until flush against the switch body. Verify that the ohmmeter indicates closed switch contacts. If the contacts are not closed, the switch is defective, and must be replaced.

6. Pivot the float switch away from the body until it is within 10 degrees of its stop. Verify that the switch contacts are open. If the contacts are not open, the switch is defective, and must be replaced.

7. Using a soft clean cloth, dry the tank side wall around the 5/8" hole. Apply pipe joint compound to the threads of the switch body and mounting nut, and their mating surfaces with the tank wall. Install the switch into the tank so the float pivots upward, aligning its pivoting axis parallel to the tank bottom. Firmly tighten the switch mounting nut.

8. Attach ohmmeter leads to the switch leads and verify the switch contacts are closed. Plug the tank outlet fitting and fill the tank with water until the switch contacts open. Continue filling the tank until

the water level rises an additional 2". Verify that the switch contacts are still open. Unplug the tank outlet and verify that the switch contacts close when the water level drops to approximately the 1/3 full point, and go to step 9. If the switch contacts do not respond properly to changing water level, check to verify that the switch is properly installed and the float pivots freely. Verify that the float is at least 1/4" away from any part of the tank. Correct any installation problems. If the switch has been properly installed, it is defective and must be replaced.

9. Drain water from the tank and install the cap, tightening it firmly. Construct a wood frame 3" to 4" high to secure the tank against sliding within the trunk. Drill a hole or cut a notch in the frame large enough to clear the tank outlet while the tank is being installed or removed. If necessary, cut a notch to clear the switch mounting nut and wires.

10. Drain water from the tank and install the cap, tightening it firmly. Construct a wood frame 3" to 4" high to secure the tank against sliding within the trunk. Drill a hole or cut a notch in the frame large enough to clear the tank outlet while the tank is being installed or removed. If necessary, cut a notch to clear the switch mounting nut and wires. Fasten the frame to the trunk floor at the desired location.

11. Locate a convenient spot on the vehicle chassis close to the water tank and drill a 3/32" grounding ring terminal attachment hole for the tank switch. Using a clean rag and solvent, remove dirt or debris from around the hole. Grind or use sandpaper to remove paint, or any other insulating material, from the area around the hole. Strip 1/2" of insulation from the end of one switch wire and crimp a large ring terminal onto the wire. Do not attach the ring terminal until instructed to do so in step 15.

**NOTE:** If, as recommended, the water pump will be installed within the engine compartment, high-low temp silicone tubing will be used to connect the tank to the pump. If the pump is installed within the trunk area, the tube connecting the pump to the check valve will be pressurized (up to 85 psi) and silicone braid reinforced tubing must be used. If the pump is not self-priming, it must be installed in the trunk.

12. Determine the length of tubing needed to reach from the pump or water tank to the engine compartment. If the pump will be located within the engine compartment, go to step 14. If the pump will be located within the trunk, go to step 13.



13. Mount the pump at the desired location within the trunk. Determine the length of tubing needed to attach the tank to the pump. Cut high-low temp tubing to the required length and slide onto the tank fitting. Secure the tubing with two small stainless steel hose clamps and tighten firmly. Slide the tank into the wood frame. Slide two small stainless steel hose clamps onto the tank tube and slide the tube onto the pump inlet fitting. Slide the hose clamps over the fitting and tighten firmly. Slide braid tubing onto the pump outlet fitting. Slide two small stainless steel hose clamps over the fitting and tighten firmly. Go to step 15.

14. Cut high-low temp tubing to the required length and slide onto the tank fitting. Secure the tubing with two small stainless steel hose clamps and tighten firmly. Slide the tank into the wood frame.

15. Attach the tank ring terminal to the 3/32" hole in the chassis with a sheet metal screw. Apply a heavy layer of petroleum jelly or grease over the terminal and screw.

16. Strip 1/2" of insulation from the end of the remaining switch wire and crimp a butt connector onto the wire. Determine the length of hookup wire needed to extend at least 3' into the engine compartment and cut to length. Strip 1/2" of insulation from the end of the hookup wire and crimp it to the butt connector. If the pump is installed in the trunk, repeat this procedure to splice an equal length of hookup wire to each pump power lead.

17. Route the tank and pump wires and tubing through the vehicle structure. Be sure to install a 3/4" ID grommet wherever an access hole must be drilled. Use tie-wraps about every 6" to secure the wire and tubing bundle. To prevent crushing the tubing, do not over-tighten the tie-wraps.

18. Securely mount the water pump in the engine compartment if the pump was not installed in the trunk. Slide two small stainless steel hose clamps onto the high-low temp tubing. Install tubing onto the pump inlet fitting and firmly tighten the hose clamps.

## HyTronics Module

### Materials List:

- Purchase specific electronic components as called for in schematic diagrams of Figure 5 on page 13, Figure 6 on page 15, and Figure 7 on page 17 (available at Radio Shack).

## Materials List: (continued)

- Two 12-Position Male Interlocking Connectors (Radio Shack Part #: 274-232).
- Two 12-Position Female Interlocking Connectors (Radio Shack Part #: 274-242).
- One Universal Component Board (Radio Shack Part #: 276-168).
- One PC Board Kit (Radio Shack Part #: 267-1576).
- One Enclosure 8" x 6" x 3" (Radio Shack Part #: 270-1809)

## Materials Source:

Radio Shack (Nationwide stores).

**NOTE:** Since both the electrode circuit (Figure 5) and coil circuit (Figure 6) operate at relatively low frequencies, physical layout of the HyTronics module components is not critical. Mount components using the Universal Component Board, or design and create your own PC Board layout using the PC Board Kit (even includes needed chemical solutions). The recommended Enclosure provides protection for the HyTronics circuits and is attractive and easy to mount.

**NOTE:** The electrode, coil, and indicator circuits may be built on the same board or on separate boards, using the side-board mounting feature of the recommended Enclosure.

1. Referring to Figure 5 on page 13, build the electrode circuit using components as detailed.
2. Referring to Figure 6 on page 15, build the coil circuit using components as detailed.
3. Referring to Figure 7 on page 17, build the indicators circuit using components as detailed.

**NOTE:** A hole must be drilled in the HyTronics module enclosure for routing wires to the 9-position indicators panel connector. A second hole must also be drilled for routing wires to two 12-position connectors for all other system components. Be sure to install an appropriately sized grommet in each hole.

4. Drill a hole in the enclosure and install a 3/8" ID grommet. Cut eight (8) 1-foot lengths of hookup wire and strip 1/2" of insulation from one end of each wire. Route one wire through the grommet and solder it to the HyTronics "Ground" (-) bus (see Figure 5 on page 13) and label the

wire. Refer to the following Figures to solder the seven remaining LED and bulb socket wires (be sure to label each wire):

PWR ON - Figure 5 on page 13.

All other LED's - Figure 7 on page 17.

Positive (+) bulb socket center connector wire - Figure 7.

5. Cut the eight wires to equal length and strip 1/4" of insulation from the end of each wire. Connect the wires to the 9-position female interlocking connector. Be sure the wire label at each position corresponds to the wire label at each position of the male 9-position connector. After connecting wires, remove all labels. Secure the wires with a tie-wrap placed about every 3" along the length of the bundle.

6. Drill another hole in the enclosure and install a 1/2" ID grommet. Cut nineteen (19) 1-foot lengths of hookup wire and strip 1/2" of insulation from one end of each wire. Solder two wires to the appropriate terminals for the Generator electrodes (Figure 5), and two wires to the appropriate terminals for the Generator coil (Figure 6). Solder one wire to the appropriate terminal of the pump circuit (Figure 7). Solder one wire to the appropriate terminal for the Generator water level switch (Figure 7). Solder five wires before the fuse connection (battery + side of power bus, see Figure 5) and five wires to the negative (-) bus. Solder one wire to the throttle 10K resistor (Figure 5). Solder two wires for the tank water level switch (Figure 7). Be sure to appropriately label each wire.

**NOTE:** Two connectors are used to provide extra positions for future expansion, modifications, and design improvements. Be sure to use a male 12-position interlocking connector and a female 12-position interlocking connector to prevent accidental connections.

7. Cut the nineteen wires to equal length and strip 1/4" of insulation from the end of each wire. Connect any nine wires to a 12-position male interlocking connector. Connect the remaining nine wires to a 12-position female interlocking connector. Secure the wires with a tie-wrap placed about every 3" along the length of the bundle.

8. Attach the HyTronis module under the dash panel and as far forward as practical. Connect the 9-position interlocking connectors of the module and dash indicators.

## Carburetor Adapter

**NOTE:** Since hundreds of various carburetors exist, I recommend contacting Impco to purchase a carburetor adapter. They deal almost exclusively in gasoline engine fuel conversion systems, have thousands of options available, and have been in business for nearly 50 years. Describe your vehicles' engine and the HydroStar system, and ask for their recommendations. In particular, inquire about the possibility of installing a Beam-Garretson Carburetor Adapter.

1. Install an appropriate carburetor adapter on your engine. Contact a company experienced in gasoline conversion systems, explaining that the HydroStar system is designed for switching back and forth between hydrogen and gasoline fuels. Here's a company I highly recommend:

Impco Technologies  
16804 Gridley Place  
Cerritos, CA 90703  
Phone: 1-562-860-6666 Fax: 1-562-860-3088

## Throttle Assembly

**NOTE:** The HyTronics throttle uses a high quality precision pot (potentiometer) designed for reliability and durability (over 5 million complete revolutions). Cheap pots will soon fail or cause problems; do not substitute a cheap pot.

### List of Materials:

- One Precision Pot, Series 578, 100K  
(Clarostat Part #: 578 X 1 G 32 P 104 S W).
- One 1-foot length CPVC Rod, 3/4" diameter  
(US Plastic Part #: 43182).

### Materials Source:

State Electronics  
36 Route 10  
East Hanover, NJ 07936  
Phone: 1-973-887-2550 Toll Free: 1-800-631-8083  
Fax: 1-973-887-1940

United States Plastic Corp (see page 22 for ordering details).

**NOTE:** Figure 21 on page 70 depicts a typical HyTronics throttle assembly. Since hundreds of various throttle linkages are in use, the following procedure is offered as a general guideline.

**NOTE:** The pot mounting bracket is designed to allow pot centering (housing rotation) and precise adjustment of throttle sensitivity (bracket rotation). The throttle linkage sleeve allows precise pot rotation limit adjustments (idle to full throttle) when combined with bracket rotation.

1. Determine the best location in the engine compartment for installing the sleeve and arm assembly and pot mounting bracket.
2. Fabricate a pot mounting bracket with dimensions indicated in Figure 21 from 1/8" CPVC sheet. If necessary, modify the bracket size and attachment points to suit your vehicle. Do not cut the 3/32" slot until instructed to do so in step 6.
3. Cut a 1-1/2" length of 3/4" diameter CPVC rod. Locate a convenient spot. Measure the diameter of the existing throttle linkage. Drill a hole with the measured diameter lengthwise through the rod. Using a thin-blade saw, cut the rod in half lengthwise. Using a belt sander, sand a flat surface at least 1/4" wide onto one rod half.
4. Cut a 1/2" x 1-1/4" sleeve arm from 1/8" CPVC sheet. Drill a 7/64" hole in one end of the arm about 1/4" from the end. Using a drill or countersink tool, bevel each end of the hole about 1/16" deep. Apply primer, and then cement, to the mating surfaces of the arm and sleeve and join the parts. Allow the parts to air dry for at least 2 hours and then dress cut edges of all throttle parts with sandpaper.
5. Referring to Figure 5 on page 13, position the shaft of the 100K throttle potentiometer (pot) at the midpoint of its range of rotation. Using a marking pen, mark an alignment line between the pot shaft and bushing at the point shown in Figure 21 on page 70. Using a #41 drill bit, drill a hole in the shaft at a point in line with the shaft alignment mark, and 3/16" in from the shaft end.
6. Cut a 6" length of 3/32" stainless steel welding rod. Temporarily install the pot into the 3/8" hole in the mounting bracket. Slide the welding rod into the shaft hole. Align the shaft and bushing marks and rotate the pot body so that the rod points directly upward (parallel with the front edge of the bracket). Place a mark at the point where the anti-rotation pin contacts the bracket. Remove the pot and rod from the

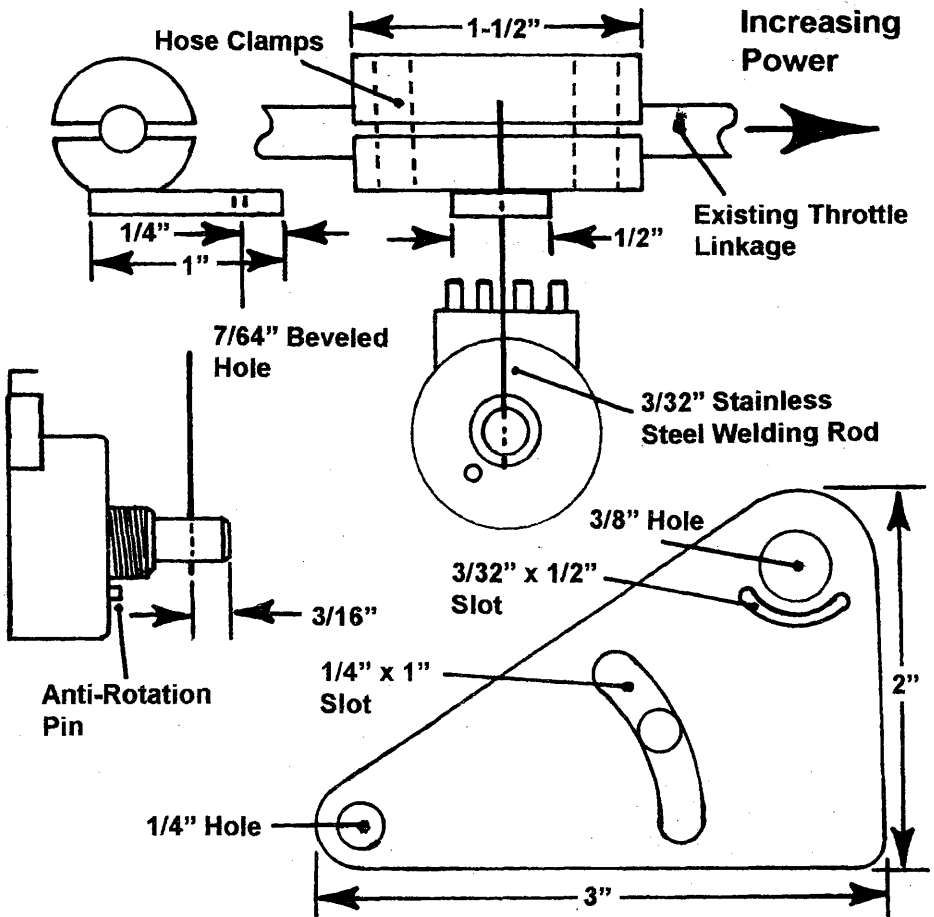

**Throttle Assembly Details  
Figure 21**

bracket. As shown in Figure 21, cut a curved  $3/32''$  wide slot extending  $1/4''$  from each side of the marked point. Temporarily install the pot onto the bracket and check that the anti-rotation pin fits into the slot and does not bind in the slot as the pot body is rotated. If necessary, and using a small fine-tooth file, file the slot until the pot body rotates freely. Dress the slot edges with sandpaper.

7. Attach the pot to the bracket with the furnished nut and lock washer. Temporarily install the rod into the shaft hole. Rotate the pot body to align the rod parallel with the front edge of the bracket and firmly tighten the mounting nut. Using a file, square off both ends of the rod and deburr with sandpaper or a fine-tooth file. Using MEK or acetone and a soft clean cloth, clean the pot shaft and rod. Flush the hole in the shaft with MEK or acetone.

8. Mix a small quantity of high quality epoxy such as J-B WELD. Using a precision instrument such as a toothpick, coat the shaft hole with a thin layer of epoxy. Apply a thin layer of epoxy to one end of the rod and insert it into the shaft hole, allowing it to extend about 1/8" beyond the end of the hole. Form a small fillet of epoxy around the junction of the rod and shaft at both sides of the shaft. Allow the epoxy to cure for at least 24 hours before going to step 33.

9. Referring to Figure 21, attach the sleeve and arm assembly to the throttle linkage using a small hose clamp at each end. Locate the pot directly below the arm with the rod protruding through the hole in the arm. Position the bracket fore or aft and sideways until the rod is square with the sleeve arm and parallel with the front edge of the bracket when the throttle linkage is approximately at its midpoint of travel. Position the bracket up or down until the rod rotates through an angle of approximately 60 degrees each side of center as the throttle linkage moves through its full range.

10. Using two 1/4" bolts, washers, and locknuts, attach the bracket to the engine structure. Position the bolt in the slot at approximately the slot midpoint to allow the pot to move up or down for precise adjustment. Loosen the bolts slightly and pivot the bracket up and down. Check that the bolt does not bind in the slot at any point. If necessary, and using a small fine-tooth file, file the slot until the pot body rotates freely. Dress the slot edges with sandpaper.

11. Check that the pot rod does not bind in the arm hole as the throttle linkage is moved through its full range of travel. If necessary to eliminate binding, rotate the pot slightly up or down and/or slide the sleeve assembly slightly fore or aft. Firmly tighten the bracket bolts and sleeve hose clamps.

## **Preliminary Assembly and Testing**

**CAUTION: DO NOT ATTEMPT TO SOLDER WIRES DIRECTLY TO THE FOUR GENERATOR ELECTRODE AND COIL PINS.**

**EXCESS HEAT WILL DAMAGE THE EPOXY BOND, POSSIBLY CAUSING GAS AND/OR WATER LEAKAGE.**

- 1. Install a male crimp-on snap connector on each of the four electrode and coil pins of the Generator. Securely install the Generator in the engine compartment using 1/4" bolts, washers, and locknuts. Be sure the Generator is level with the vehicle frame. If the water pump is installed in the trunk, go to step 3. If installed in the engine compartment, go to step 2.**
- 2. Cut a length of silicone braid tubing to connect the water pump outlet to the 3/8" fitting on the side of the Generator housing near the bottom. Allow some slack in the tubing. Go to step 3.**
- 3. If the water pump has an internal check valve, slide two small hose clamps onto the water tubing and install onto the 3/8" barb fitting on the side of the Generator housing near the bottom. Allow some slack in the tubing and firmly tighten the clamps. If the pump does not have an internal check valve, install a check valve in the tubing a few inches from the barb fitting in the side of the Generator. Allow some slack in the tubing. Use two small hose clamps on each barb fitting and tighten firmly. Be sure to install the check valve so that the flow direction arrow on the valve points toward the Generator.**
- 4. Cut two (2) 3" lengths of braid tubing and attach them to each end of a check valve with small hose clamps. Tighten the clamps firmly. Using two small hose clamps, attach a valve hose to the carb adapter on the engine with the valve arrow pointing toward the adapter. Tighten the clamps firmly.**
- 5. Using two hose clamps, attach the flame arrestor to the check valve hose. Firmly tighten the clamps. Cut a length of braid tubing to connect the 3/8" barb fitting on top of the Generator to the flame arrestor. Slide four small hose clamps onto the tubing and connect the tubing between the Generator and flame arrestor. Allow some slack in the tubing and firmly tighten the clamps.**
- 6. Using two small hose clamps, attach the pressure gauge tubing to the 1/8" fitting on top of the Generator. Allow some slack in the tubing and firmly tighten the clamps.**
- 7. Cut four (4) 5-foot lengths of hookup wire and strip 1/2" of insulation from one end of each wire. Twist the stranded ends of two wires together and trim the ends to a length of 3/8". Crimp a ring terminal to**



the spliced wires and attach the terminal to the HyTronics power switch. Repeat the procedure for the other two wires. Mount the switch at a convenient point on the dash. Route one pair of switch wires to the vehicle positive (+) power bus that is always "hot" (the battery side of the bus as shown in Figure 5 on page 13). Cut the wires to length and strip 1/2" of insulation from the wire ends. Twist the wires together, trim to 3/8", and crimp a ring terminal (or other appropriate connector) to the wire ends. Do not attach the terminal, or other connector, to the bus until instructed to do so in step 16.

8. Cut two (2) 5-foot lengths of hookup wire and splice together with a ring terminal as was done in step 7. Locate a convenient spot in the engine compartment to attach the ring terminal to the vehicle chassis. Drill a 3/32" hole at that location and attach the terminal following the procedure of steps 11 and 15 on pages 64 and 65.

9. Route the two wires through the grommet installed in the engine compartment firewall. Allowing slack in the wires, cut the wires to length to reach the two 12-position connectors of the HyTronics module. Trim 1/4" of insulation from the end of each wire and connect each wire to a negative (-) bus position of either of the 12-position interlocking connectors (see step 6 on page 67).

10. Route the remaining pair of switch wires to the connectors and cut the wires to length, allowing some slack in the wires. Connect the wires to the connectors at two of the battery positive (+) power bus positions in the same manner as was done in step 9.

11. Cut four (4) wires of appropriate length to connect the Generator coil and electrode pins to the connectors. Strip 1/4" of insulation from each wire end and install a female crimp-on snap connector to each wire. Attach the connectors to the Generator terminals. Route the wires to the HyTronics connectors and cut the wire ends to equal length. Strip 1/4" of insulation from each wire end and connect each wire to the appropriate position of the HyTronics connectors.

12. Referring to Figure 7 on page 17, connect the tank water level and Generator water level switch wires to the appropriate positions of the HyTronics connectors. Using butt connectors, splice hookup wire to the switch wires as required to reach the HyTronics connectors.

13. Cut two lengths of hookup wire to connect the throttle pot to the HyTronics connectors. Strip 1/4" of insulation from one end of each wire and solder each wire to the pot terminals. Slide a 1" length of

heat shrink tubing onto each wire and over the soldered terminals and shrink the tubing.

14. Route the pot leads to the HyTronics connectors and cut their ends to equal length. Strip 1/4" of insulation from the end of each wire. Connect one pot lead to a battery positive (+) power bus connector position. Connect the other lead to the connector position leading to the 10K resistor lead (see Figure 5 on page 13). Rotate the pot shaft to its midpoint position.

**CAUTION: DO NOT CONNECT THE WATER PUMP LEADS NOR ADD WATER TO THE TANK UNTIL INSTRUCTED TO DO SO IN STEP 1 ON PAGE 77, "FINAL ASSEMBLY AND TESTING."**

15. Using an ohmmeter, verify that the HyTronics power switch is in the OFF position. If not, place the switch in the OFF position.

16. Connect the switch ring terminal, or other connector, to the battery positive (+) power bus.

**CAUTION: POWER WILL BE APPLIED TO THE HYDROSTAR SYSTEM IN STEP 18. ANY INCORRECT ELECTRICAL OR ELECTRONIC CONNECTION CAN LEAD TO SYSTEM OR COMPONENT FAILURE AND/OR DAMAGE. BE SURE TO DOUBLE-CHECK ALL ELECTRICAL AND ELECTRONIC CONNECTIONS BEFORE APPLYING POWER.**

17. Double-check all electrical and electronic connections of the HydroStar system. Correct any connection errors as required. Connect the two 12-position interlocking connectors of the HyTronics module to the matching system connectors. Verify that all system connectors are properly engaged. If still in place, remove the HyTronics module enclosure cover.

**CAUTION: DO NOT ATTEMPT TO START THE ENGINE UNTIL INSTRUCTED TO DO SO. THIS IS A PRELIMINARY TEST TO VERIFY BASIC SYSTEM FUNCTIONING. IF ANY PROBLEM EXISTS, SHUT OFF POWER IMMEDIATELY.**

18. Immediately after applying power, check for the following system responses in the order noted. If any problem exists, shut power OFF immediately.

- Smoke and/or electrical sparking does not occur.
- Electrical overheating of any system component does not occur.

- On the indicator panel, check that the LED's function as follows:
  - "PWR ON, PUMP ON, and GEN WATER LOW" LED's are lit.
  - "TANK WATER LOW" LED is blinking.
- On the indicator panel, check that the gauge lights are lit.

Place the HydroStar power switch to the ON position. Verify that no problem exists. If a problem exists, turn power OFF immediately.

19. If no problem exists, go to step 20. If a problem exists, troubleshoot to locate and repair (or replace) the failed component. After replacement or repair is accomplished, go back to step 18.

20. Using your fingers as heat sensors, check that no system component is overheating. If overheating has not occurred, go to step 21. If overheating occurred, turn power OFF and return to step 19.

21. Check that the vehicle gas pedal is in the full idle position. If not, place it in the idle position. Connect a digital voltmeter to pin 6 of amplifier LM741 (refer to Figure 5 on page 13) and record the voltage level there. If voltage is present, go to step 22. If no voltage exists, a component is defective and must be replaced. After replacing the component, go back to step 18.

**NOTE:** As the gas pedal is moved from idle to full power, the voltage level at pin 6 of amplifier LM741 should increase slightly. Expect an increase of approximately 1 VDC to 4 VDC.

22. Move the gas pedal to full power. Record the voltage level at pin 6. Compare the voltage with that recorded in step 21. If the voltage level has increased by at least 1 VDC, go to step 23. If the voltage level has not changed at all, a component is defective and must be replaced. After replacing the component, go back to step 21.

23. Rotate the 20K "Throttle Adjust" pot from stop to stop. Verify that voltage at pin 6 varies as the pot is rotated. If voltage varies, go to step 24. If voltage does not vary, a component is defective and must be replaced. After replacing the component, repeat this procedure.

24. Set the "Throttle Adjust" pot to its midpoint of rotation.

**NOTE:** A highly stable square wave pulse is created by the NE555 controller. As the gas pedal is moved toward full power, the input voltage to the controller from the LM741 amplifier increases,

increasing the pulse width ratio of the controller square wave output at pin 3.

25. Connector an oscilloscope lead to pin 3 of the NE555 controller. Verify that a square wave pulse exists and that the pulse width ratio increase as the gas pedal is moved from full idle to full power. If a square wave exists and the pulse width ratio increases, go to step 26. If a pulse does not exist, or the pulse width ratio does not increase as the gas pedal is moved, a component is defective and must be replaced. After replacing the component, repeat this procedure.

26. Rotate the 2K "pulse width adjust" trim pot from stop to stop. Verify that the pulse width changes as the pot is rotated. If the pulse width changes, go to step 27. If the pulse width does not change, a component is defective and must be replaced. After replacing the component, repeat this procedure.

27. Set the 2K trim pot to its midpoint of rotation.

**NOTE:** The frequency of the square wave pulse falls in the range of 15KHz to 20 KHz. The trigger oscillator circuit provides variable frequency input pulses to the NE555 controller in response to adjustment to the 2K trim pot and dip switch settings.

28. Connect the oscilloscope lead to pin 3 of the NE555 controller. Verify that square wave frequency changes as the oscillator 2K pot is rotated. If the frequency changes, go to step 29. If the frequency does not change, a component is defective and must be replaced. After replacing the component, repeat this procedure.

29. Set the oscillator pot to its midpoint of rotation.

**NOTE:** Referring to Figure 6 on page 15, the frequency of the coil circuit is controlled by the CD4059A Divide by N Counter, and falls in the range of 15Hz to 20Hz. Input to the counter is received from the electrode circuit (Figure 5 on page 13). When the frequency of the electrode circuit is changed, the frequency of the coil circuit changes accordingly. Pulse width of the coil circuit is adjusted with the 10K "Pulse Width Adjust" pot.

30. Connect an oscilloscope lead to pin 8 of the NE555 controller. Rotate the "Pulse Width Adjust" pot from stop to stop. Verify that the pulse width changes as the pot is rotated. If the pulse width changes, go to step 31. If the pulse width does not change, a component is defective

and must be replaced. After replacing the component, repeat this step.

31. Set the "Pulse Width Adjust" pot to its midpoint of rotation.

32. Connect a digital voltmeter lead to pin 8 of the NE555 controller. Rotate the 10K "Strength Adjust" pot from stop to stop. Verify that the voltage level changes as the pot is rotated. If the voltage level changes, go to step 33. If the voltage level does not change, a component is defective and must be replaced. After replacing the component, repeat this step.

33. Set the "Strength Adjust" pot to its midpoint of rotation.

34. Referring to Figure 5 on page 13, set the dip switches according to oscillator CD4069 manufacturer instructions to obtain a frequency between 15 KHz and 20 KHz.

Connect an oscilloscope or frequency meter lead to pin 6 of oscillator CD4069. Verify that the oscillator frequency is between 15 KHz and 20 KHz. If the frequency is not between 15 KHz and 20 KHz, adjust the 2K "Frequency Adjust" pot to obtain a frequency within that range. If the correct frequency cannot be obtained, there is a defective component (most likely CD4069) in the oscillator circuit. Locate and replace the defective component and return to this step.

35. Referring to Figure 6 on page 15, and using an oscilloscope or frequency meter, verify that the frequency of the pulse appearing at the collector of component 2N3055 is from 15 Hz to 20 Hz. If the frequency is within that range, go to step 37. If the frequency is not within that range, go to step 36.

36. Set the "Divide by N" counter for an N factor of 1,000 according to the manufacturers' instructions. Verify a frequency of 15 Hz to 20 Hz at the collector of component 2N3055. If the frequency is within that range, go to step 37. If the frequency is not within that range, a component is defective and must be replaced. After replacing the component, go back to step 35.

37. Shut power OFF.

## Cylinder Head Temperature

**NOTE:** Hydrogen burns slightly hotter than gasoline, so you should expect slightly higher cylinder head temperature (CHT). It's a good

idea to establish CHT reference points by driving first on gasoline, and I recommend that approach. The HydroStar uses a very high quality fast-response CHT gauge, sensing CHT directly from the base of a sparkplug.

1. Drive your vehicle for at least 15 minutes (30 minutes in cold weather) on open highway to assure that the engine is up to normal operating temperature. Note and record CHT (in degrees Fahrenheit) under each of the following driving conditions:

- Parked at full idle, transmission in "neutral," for three minutes.
- 25 MPH in residential areas for at least two minutes.
- 60 MPH (or full power) on steep grade for at least 30 seconds.

## **Final Assembly and Testing**

1. If the water pump is installed in the trunk, connect its positive (+) power lead to a battery positive (+) power bus connector position. If the pump is installed in the engine compartment, splice a hookup wire to its positive (+) power lead with a butt connector and connect it to a battery positive (+) power bus connector position. In like manner, connect the pump negative (-) power lead to the connector position leading to the collector lead of the E3055T switch as shown on Figure 7 on page 17.

2. Fill the HydroStar tank with water. Check that no water leaks from the tank or any of its tubing connections. If necessary, correct or repair any leaks.

**NOTE:** Your vehicle is now ready to run on water for the first time with the HydroStar system. For initial operation, it's best that the engine is already warmed up to normal operating temperature. If not up to temperature, drive on gasoline power for at least 15 minutes.

3. Park your vehicle on a level surface with parking brake engaged and transmission in neutral. Lift the trunk lid if the water pump is installed in the trunk. Lift the hood, or engine compartment cover.

4. Following manufacturers' instructions, set the carburetor adapter for hydrogen operation.

**CAUTION:** CLOSELY MONITOR THE PRESSURE GAUGE. IF GENERATOR GAS PRESSURE EXCEEDS 70 PSI, SHUT POWER OFF IMMEDIATELY. AS A SAFETY PRECAUTION, PRESSURE EXCEEDING 85 PSI IS VENTED BY THE PRESSURE RELIEF

**VALVE. DO NOT DEPEND ON THE RELIEF VALVE TO RELIEVE EXCESS PRESSURE.**

**IF ANY SYSTEM PROBLEM EXISTS, SHUT OFF POWER IMMEDIATELY.**

**Note:** At idle, gas pressure should be in the range of about 12 PSI to 28 PSI. At full power, about 28 PSI to 62 PSI.

5. Referring to Figures 5 and 6 on pages 13 and 15, set the "Throttle Adjust," "Pulse Width Adjust" (one in each circuit), "Frequency Adjust," and "Strength Adjust" pots to their midpoint of rotation. Immediately after applying power, check for the possibility of any of the following problems. If any problem exists, immediately shut power OFF.

- Smoke and/or electrical sparking.
- Generator pressure exceeds 70 PSI.
- Electrical overheating of any system component.
- Gas and/or water leakage from the Generator.
- Water leakage from tubes, fittings, and other components.

Turn power ON. Wait for Generator pressure to reach at least 25 PSI. If Generator pressure will not reach at least 25 PSI, go to step 7. When pressure reaches at least 25 PSI, start the engine. Run the engine at idle speed until instructed to do otherwise. Check that none of the problems noted above exists. If any problem exists, immediately shut power OFF and go to step 6.

Check the following "If" conditions:

- If the engine starts, go to step 26 on page 83
- If the engine will not start, go to step 7.
- If any problem noted at the beginning of this step exists, go to step 6.

6. Verify that power is OFF. A system component has either failed or is defective. Troubleshoot to locate the component. Repair or replace the component and go back to step 5.

7. Shut power OFF. Obtain a small bucket or large container. Open the Generator drain cock and drain until empty. Close the drain cock. If no water drained, go to step 8. If at least some water drained, go to step 14.

8. Turn power ON. Verify that the water pump runs. If the pump

runs, go to step 9. If the pump does not run, turn power OFF and go to step 25.

9. Verify that water is reaching the pump inlet. If water reaches the inlet, go to step 13. If water does not reach the inlet, go to step 10.

10. Disconnect the tubing from the pump outlet. Verify that water now reaches the pump inlet. If water reaches the inlet, go to step 12. If water does not reach the inlet, go to step 11.

11. Turn power OFF. Check for restrictions in the tubing leading to the pump inlet. If a restriction is located, repair as necessary, reconnect tubing, and go back to step 5 on page 79. If no restriction exists, the pump is defective and must be repaired or replaced. After pump repair or replacement, reconnect the pump and go back to step 5 on page 79.

12. Verify that water is flowing from the pump outlet and turn power OFF. If water was flowing, the check valve is either defective or has been installed backward. Replace the check valve or reinstall it with the flow arrow pointing towards the Generator, reconnect tubing, and go back to step 5 on page 79. If water was not flowing, the pump is defective and must be repaired or replaced. After pump repair or replacement, reconnect the pump and go back to step 5 on page 79.

13. Disconnect the tubing from the pump outlet. Verify that water now flows from the pump outlet and turn power OFF. If water was flowing, the check valve is either defective or has been installed backwards. Replace the check valve or reinstall it with the arrow pointing towards the Generator and go back to step 5 on page 79. If water was not flowing, the pump is defective and must be repaired or replaced. After pump repair or replacement, reconnect the pump and go back to step 5 on page 79.

14. Turn power ON. Verify that no water is present in the tubing leading from the Generator to the flame arrestor. Turn power OFF. If water was present, go to step 15. If water was not present, go to step 17.

15. Refer to Figure 7 on page 17. Cut the Generator water level switch wire connected to the HyTronics positive (+) power bus within about 6" of the Generator. Strip 1/4" from each end of the cut lead. Connect an ohmmeter lead to the wire exiting the Generator and the other lead to vehicle ground (-). Verify that the ohmmeter indicates that the switch



contacts are open. If the switch contacts are open, go to step 16. If the switch contacts are closed, the switch slosh shield has been incorrectly installed. Referring to step 9 on page 46, remove the slosh shield and reinstall it. Be sure the shield is accurately centered around the switch float. Reconnect the switch wires with a butt connector and go back to step 5 on page 79.

16. Reconnect the switch wires with a butt connector. A defective component exists in the pump control circuit. Replace the defective component and go back to step 5 on page 79.

17. Verify that the check valve in the tubing leading to the engine is installed with the flow arrow pointing toward the engine. If the check valve is installed correctly, go to step 18. If the check valve is not installed correctly, remove it from the tubing and reinstall it correctly. Go back to step 5 on page 79.

18. Set the water container on a level surface, mark the water level on the side of the container, and dispose of water. Close the Generator drain cock.

19. Disconnect the gas outlet hose from the top of the Generator. Turn power ON, wait for the water pump to stop running, and shut power OFF. Open the drain cock and drain water into the container until the Generator is empty. Close the drain cock. Check the water level and dispose of water. If the water level was higher than the level marked in step 18, go to step 20. If the water level was about the same, go to step 26.

20. Reconnect the tubing and disconnect the tubing from the carburetor adapter. Turn power ON, wait for the water pump to stop running, and shut power OFF. Open the drain cock and drain water into the container until the Generator is empty. Close the drain cock. Check the water level and dispose of water. If the water level was higher than the level marked in step 18, go to step 21. If the water level was about the same, go to step 22.

21. The carburetor adapter (or its associated parts) is either defective or requires adjustment. Following the manufacturers' instructions, either adjust the adapter or return it to the manufacturer for adjustment or repair. After adjustment or repair, reconnect the tubing and go back to step 5 on page 79.

22. Reconnect the tubing and disconnect the tubing between the

flame arrestor and check valve. Turn power ON, wait for the water pump to stop running, and shut power OFF. Open the drain cock and drain water into the container until the Generator is empty. Close the drain cock. Check the water level and dispose of water. If the water level was higher than the level marked in step 18, go to step 23. If the water level was about the same, go to step 24.

23. The check valve is defective. Replace the valve, reconnect the tubing, and go back to step 5 on page 79.

24. The flame arrestor has been constructed incorrectly. Remove the flame arrestor from the tubing, remove its end fittings, and dispose of the flame arrestor. Return to the "Flame Arrestor" procedure on page 41. Following the instructions there, construct a new flame arrestor. Allow the CPVC cement to air dry for at least 24 hours. Apply a thin coating of pipe joint compound to the tapped threads in the ends of the flame arrestor and fittings. Thread the fittings into the flame arrestor and tighten firmly. Install the new flame arrestor into the tubing and go back to step 5 on page 79.

25. Turn power OFF. The most likely candidate for pump failure is the pump itself. Cut the pump negative (-) bus wire and check pump operation while disconnected from the HyTronics module. If the pump still does not run, or draws current in excess of 15 amps during start up, repair or replace it and reconnect the pump wires using butt connectors. Also check to see if the main fuse has blown (refer to Figure 5 on page 13). If the fuse has blown, replace it and go back to step 5 on page 79.

If the pump operates normally, reconnect the wire with a butt connector. Check to verify that the E3055T switch (refer to Figure 7 on page 17) has not failed due to pump current overload. If the switch has failed, replace it with a switch of higher current capacity and go back to step 5 on page 79. If the switch has not failed, cut the Generator water level switch wire connected to the HyTronics positive (+) power bus within about 6" of the Generator. Strip 1/4" from each end of the cut lead. Connect an ohmmeter lead to the wire exiting the Generator and the other lead to vehicle ground (-). Verify that the ohmmeter indicates that the switch contacts are closed. If the switch contacts are closed, either the pump is defective, a pump circuit component is defective (refer to Figure 7 on page 17), or wiring errors exist. Troubleshoot to locate the problem and repair or replace as necessary. After correcting the problem, go back to step 5 on page 79.

If the switch contacts are open, the switch slosh shield has been incorrectly installed. Referring to step 9 on page 46, remove the slosh shield and reinstall it. Be sure the shield is accurately centered around the switch float. Reconnect the switch wires with a butt connector and go back to step 5 on page 79.

26. Verify that no water is present in the tubing leading from the Generator to the flame arrester. If water is present, turn power OFF and go back to step 15. If water is not present, read the following notes before going to step 27.

**NOTE:** The HydroStar system is designed to operate well over a wide range of different electronic settings and adjustments. It is tolerant of just about anything short of gross adjustment errors. However, since each engine has unique requirements, obtaining optimal performance is mostly a matter of making simple trial and error adjustments.

Here are some general guidelines for gaining optimal performance by the very effective method known as “tweaking“:

- At idle, Generator pressure should be 12 PSI to 28 PSI.
- At full power, Generator pressure should be 28 PSI to 62 PSI.
- For each driving (or idle) condition, be sure CHT never exceeds 40 degrees more than the value recorded in step 1 on page 78.
- Be sure CHT never exceeds 400 degrees.

**NOTE:** Tweaking the HydroStar system is easier, safer, and faster if another person does the driving while you do the tweaking.

27. Park your vehicle with the engine at idle, transmission in neutral, and parking brake set. Wait until Generator pressure stabilizes and go to step 30.

28. Drive your vehicle at 25 MPH in residential areas. If the “Frequency Adjust” pot is rotated CW to increase Generator pressure, go to step 30.

If the “Frequency Adjust” pot is rotated CCW to increase Generator pressure, go to step 37.

29. Drive your vehicle at 60 MPH (or full power) on a steep grade. If the “Frequency Adjust” pot is rotated CW to increase Generator pressure, go to step 30.

If the “Frequency Adjust” pot is rotated CCW to increase Generator

pressure, go to step 37.

30. Referring to Figure 5 on page 13, rotate the "Frequency Adjust" trim pot fully counterclockwise (CCW). Slowly rotate clockwise (CW). If Generator pressure starts to increase before rotating about 90% of total rotation, go to step 31. If pressure does not increase, go to step 37.

31. Rotate slowly CW until pressure stops increasing. Rotate an additional 10 degrees. Wait until pressure stabilizes and record pressure. Slowly rotate CCW until pressure starts to drop. Slowly rotate CW until pressure increases to the recorded value. Record that the "Frequency Adjust" pot is rotated CW to increase pressure. If your HydroStar is being tuned while idling, go to step 32. If your vehicle is being tuned while driving, go to step 43.

32. Rotate the "Pulse Width Adjust" trim pot fully CCW. Slowly rotate CW. If pressure starts to increase before rotating about 90% of total rotation, go to step 33. If pressure does not increase, go to step 39.

33. Rotate slowly CW until pressure stops increasing. Rotate an additional 10 degrees. Wait until pressure stabilizes and record pressure. Slowly rotate CCW until pressure starts to drop. Slowly rotate CW until pressure increases to the recorded value. Record that the "Pulse Width Adjust" pot is rotated CW to increase pressure. Go to step 34.

34. If you are tweaking your HydroStar with the engine at idle, go to step 35. If you are tweaking your HydroStar while driving, go to step 36.

35. Refer to Figure 21 on page 70. If necessary, adjust engine idle speed by loosening hose clamps and sliding the arm and sleeve assembly either fore or aft. Tighten hose clamps firmly. If pressure exceeds 28 PSI, go to step 41. If pressure is 28 PSI or less, go back to step 28.

36. If pressure exceeds 62 PSI, go to step 42. If pressure is 62 PSI or less, go to step 44.

37. Rotate the "Frequency Adjust" pot fully CW. Slowly rotate CCW. If pressure starts to increase before rotating about 90% of total rotation, go to step 38. If pressure does not increase, rotate the pot CW to its' midpoint and go back to step 32.

38. Rotate slowly CCW until pressure stops increasing. Rotate an additional 10 degrees. Wait until pressure stabilizes and record pressure. Slowly rotate CW until pressure starts to drop. Slowly rotate CCW until pressure increases to the recorded value. Record that the "Frequency Adjust" pot is rotated CCW to increase pressure. If your HydroStar is being tuned while idling, go back to step 32. If your HydroStar is being tuned while driving, go to step 43.

39. Rotate the "Pulse Width Adjust" pot fully CW. Slowly rotate CCW. If pressure starts to increase before rotating about 90% of total rotation, go to step 40. If pressure does not increase, rotate the pot CW to its' midpoint and go back to step 34.

40. Rotate slowly CCW until pressure stops increasing. Rotate an additional 10 degrees. Wait until pressure stabilizes and record pressure. Slowly rotate CW until pressure starts to drop. Slowly rotate CCW until pressure increases to the recorded value. Record that the "Pulse Width Adjust" pot is rotated CCW to increase pressure. Go back to step 34.

41. Using a marking pen, place an alignment mark on the "Frequency Adjust" and "Pulse Width Adjust" pots. Determine the amount of pressure exceeding 28 PSI. (For example; if pressure is 32 PSI, excess pressure is 4 PSI.) Reduce pressure to 28 PSI by alternately rotating each pot in the correct direction a few degrees at a time. Attempt to divide the excess pressure equally between the two pots. (For example; if excess pressure is 4 PSI, attempt to reduce pressure 2 PSI with each pot.) Go back to step 28.

42. Using a marking pen, place an alignment mark on the "Frequency Adjust" and "Pulse Width Adjust" pots. Determine the amount of pressure exceeding 62 PSI. (For example; if pressure is 70 PSI, excess pressure is 8 PSI.) Reduce pressure to 62 PSI by alternately rotating each pot in the correct direction a few degrees at a time. Attempt to divide the excess pressure equally between the two pots. (For example; if excess pressure is 8 PSI, attempt to reduce pressure 4 PSI with each pot.) Go to step 44.

43. If the "Pulse Width Adjust" pot is rotated CW to increase Generator pressure, go back to step 32.

If the "Pulse Width Adjust" pot is rotated CCW to increase Generator pressure, go back to step 39.

44. If you just completed HydroStar tuning after driving 25 MPH in residential areas, go to step 45. If you just completed HydroStar tuning after driving 60 MPH (or full power) on a steep grade, go to step 67 on page 89.

45. Referring to Figure 21 on page 70, be sure the throttle linkage moves through its full range of travel from idle to full power without binding of the rod within the arm. Perform the procedure of step 66 on page 89 before proceeding.

Drive your vehicle at 60 MPH (or full power) on a steep grade. Listen closely for the sound of engine pre-combustion ("ping"). If the engine pings, go to step 46. If the engine does not ping, go to step 56.

**NOTE:** The procedures of steps 45 through 65 tune the coil circuit to create an ideal mixture of parahydrogen (created by the coil) and orthohydrogen (created by the electrodes). Low levels of parahydrogen (too lean) can result in excessively high cylinder head temperature (CHT), a common cause of engine pre-combustion ("ping"). High levels of parahydrogen (too rich) result in low CHT; cooling combustion, decreasing efficiency, and possibly causing engine roughness.

Optimal mixture is achieved by leaning parahydrogen to the point of creating ping and then slightly richening until ping disappears. You will be sequentially "fine tuning" two different pots. It's very important to closely monitor CHT while leaning to prevent excessively high CHT; refer to CHT recorded in step 1 on page 78 for driving 60 MPH (or full power) on a steep grade. Be sure CHT does not exceed the recorded value by more than 40 degrees. Never allow CHT to exceed 400 degrees.

46. Referring to Figure 6 on page 13, Rotate the "Pulse Width Adjust" pot fully counterclockwise (CCW). If the engine pings, go to step 47. If the engine does not ping, go to step 52.

47. Rotate fully clockwise (CW). If the engine pings, go to step 48. If the engine does not ping, go to step 53.

48. Slowly rotate CCW. If CHT decreases, continue rotating CCW until CHT stops decreasing. Go to step 49. If CHT increases while rotating CCW, rotate fully CCW. Slowly rotate CW until CHT stops decreasing. Go to step 49.

49. Rotate the "Strength Adjust" pot fully CCW. If the engine pings,

go to step 50. If the engine does not ping, go to step 54.

50. Rotate fully CW. If the engine pings, rotate each pot to its' midpoint and go to step 51. If the engine does no ping, go to step 55.

51. Turn power OFF. Referring to Figure 6 on page 15, the coil circuit is not producing enough parahydrogen. Replace the 10K resistor connecting pin 3 of component NE555 to the base of component 2N3055 with a 10K pot. Adjust the pot for about 9K resistance. Go back to step 45. If you reach this step again, adjust the pot for about 8K and go back to step 45. If necessary, each time you reach this step, adjust the pot for about 1K less and go back to step 45. If the pot is eventually adjusted for 2K or less, a circuit component is defective. Locate and replace the defective component. Adjust the pot for 10K. Turn power ON and go back to step 45.

52. Slowly rotate clockwise (CW) until ping starts. Slowly rotate CCW until ping stops and continue to rotate CCW about 5 more degrees. If CHT is more than 40 degrees higher than the value recorded in step 1 on page 78, continue slowly rotating CCW until CHT decreases to 40 degrees above the recorded value. Go back to step 29.

53. Slowly rotate CCW until ping starts. Slowly rotate CW until ping stops and continue to rotate CW about 5 more degrees. If CHT is more than 40 degrees higher than the value recorded in step 1 on page 78, continue slowly rotating CW until CHT decreases to 40 degrees above the recorded value. Go back to step 29.

54. Slowly rotate CW until ping starts. Slowly rotate CCW until ping stops and continue to rotate CCW about 5 more degrees. If CHT is more than 40 degrees higher than the value recorded in step 1 on page 78, continue slowly rotating CCW until CHT decreases to 40 degrees above the recorded value. Go back to step 29.

55. Slowly rotate CCW until ping starts. Slowly rotate CW until ping stops and continue to rotate CW about 5 more degrees. If CHT is more than 40 degrees higher than the value recorded in step 1 on page 78, continue slowly rotating CW until CHT decreases to 40 degrees above the recorded value. Go back to step 29.

56. Referring to Figure 6 on page 13, Rotate the "Pulse Width Adjust" pot fully counterclockwise (CCW). If the engine pings, go to step 62. If the engine does not ping, go to step 57.

57. Rotate fully clockwise (CW). If the engine pings, go to step 63. If the engine does not ping, go to step 58.

58. Slowly rotate CCW. If CHT increases, continue rotating CCW until CHT stops increasing. Go to step 59. If CHT decreases while rotating CCW, rotate fully CCW. Slowly rotate CW until CHT stops increasing. Go to step 59.

59. Rotate the "Strength Adjust" pot fully CCW. If the engine pings, go to step 64. If the engine does not ping, go to step 60.

60. Rotate fully CW. If the engine pings, go step 65. If the engine does not ping, rotate each pot to its' midpoint and go to step 61.

61. Turn power OFF. Referring to Figure 6 on page 15, the coil circuit is producing excessive parahydrogen. Replace the 10K resistor connecting pin 3 of component NE555 to the base of component 2N3055 with a 20K pot. Adjust the pot for about 11K resistance. Go back to step 45. If you reach this step again, adjust the pot for about 12K resistance and go back to step 45. If necessary, each time you reach this step, adjust the pot for about 1K more resistance and go back to step 45. If the pot is eventually adjusted for about 18K resistance or more, a circuit component is defective. Locate and replace the defective component. Adjust the pot for 10K. Turn power ON and go back to step 45.

62. Slowly rotate clockwise (CW) until ping stops and continue to rotate CW about 5 more degrees. If CHT is more than 40 degrees higher than the value recorded in step 1 on page 78, continue slowly rotating CW until CHT decreases to 40 degrees above the recorded value. Go to step 66.

63. Slowly rotate CCW until ping stops and continue to rotate CW about 5 more degrees. If CHT is more than 40 degrees higher than the value recorded in step 1 on page 78, continue slowly rotating CW until CHT decreases to 40 degrees above the recorded value. Go to step 66.

64. Slowly rotate clockwise (CW) until ping stops and continue to rotate CW about 5 more degrees. If CHT is more than 40 degrees higher than the value recorded in step 1 on page 78, continue slowly rotating CW until CHT decreases to 40 degrees above the recorded value. Go to step 66.

65. Slowly rotate CCW until ping stops and continue to rotate CW



about 5 more degrees. If CHT is more than 40 degrees higher than the value recorded in step 1 on page 78, continue slowly rotating CW until CHT decreases to 40 degrees above the recorded value. Go back to step 29.

66. Precise throttle adjustment is easy using the special features of the HydroStar throttle assembly (refer to Figure 21 on page 70). Here's the method I recommend:

A). Disengage the arm from the throttle rod. Rotate the pot shaft through the total range of rotation required to go from idle to full power. Using a ruler, measure and record the total distance traveled by the tip of the throttle rod as the pot is rotated.

B). Rotate the pot shaft to its' midpoint of rotation and position the throttle linkage at its' midpoint of travel. Slide the arm onto the throttle rod and attach the arm and sleeve onto the throttle linkage with hose clamps.

C). Raise or lower the pot by rotating its' mounting bracket about the 1/4" bolt until throttle rod travel is equal to that recorded in paragraph A when the throttle linkage moves through its' full range of travel. If necessary, to obtain added distance between the pot and arm, the arm and sleeve assembly can be inverted to position the arm above the linkage.

D). To assure smooth operation without binding, be sure the throttle rod is squared with the surface of the arm when the linkage is at its' midpoint of travel. If necessary, rotate the pot body within the limits of the 3/32" slot and rotate the sleeve about the axis of the linkage until the throttle rod is square with the arm.

E). Adjust idle to desired speed. Operate the throttle through several cycles to verify smooth operation without binding.

F). Firmly tighten mounting bolts, hose clamps, and the pot retaining nut. With the throttle at idle position, trim the throttle rod to length so that it protrudes about 1/4" above the arm. Square the rod end with a file and deburr with sandpaper. Mix a small quantity of epoxy, such as J-B WELD, and apply into the 3/32" slot in the area of the anti-rotation pin to secure the pot against rotation.

67. While driving, verify that the four LED's operate as follows:

- Green PWR ON lights when power is ON and is not lit when power is OFF.

- Green PUMP ON and yellow GEN WATER LOW both light when the water pump is running and are not lit at all other times.
- Red TANK WATER LOW is not lit when tank water level is more than about 1/3 full, and blinks when water falls below that level.

If all four LED's operate properly, go to step 68. If not operating properly, refer to Figures 5, 6 and 7 on pages 13, 15, and 17, and troubleshoot to locate the defective component or wiring error. Repair or replace as necessary and go to step 68.

68. Congratulations, your HydroStar system is working perfectly! After about 25 hours of driving, firmly tighten hose clamps on all fittings. Happy driving!

## Helpful Hints and Tips

Here are some hints and tips to help you get the most from your HydroStar system:

### Maintenance

Your HydroStar is practically maintenance-free; just fill up with water and drive. But, tap water contains minerals which accumulate within the Generator and coat parts. The electrode gap will gradually fill with deposits, and efficiency will keep dropping until insufficient hydrogen and oxygen are available to power your engine. Prevent mineral build-up by periodically flushing and cleaning the Generator.

**Flushing** - Since it's so quick, easy, and effective, I highly recommend flushing the Generator at least every week or two. There's no need to start the engine. Simply open the drain cock and turn power ON for a minute or two. (The water pump will provide plenty of fresh water to do a good job.) Close the drain cock, wait for the Generator to pump full, and turn power OFF. Be sure to top off the water tank.

**Cleaning** - A thin layer of minerals will eventually coat the Generator parts, and must be periodically removed. Depending on the mineral content of the water and the amount of driving, cleaning requirements may vary considerably. To be on the safe side, I recommend cleaning every month or two. A mildly acidic mineral deposit cleaner such as "CLR" (available at large grocery and hardware stores) works very well. Dozens of similar products are on the market; most being used to clean deposits from humidifiers. Any store carrying humidifiers should also have an effective cleaner.

Make sure power is OFF. Drain the Generator, disconnect the outlet tube at the flame arrestor, and close the drain cock. Wearing protective gloves, mix cleaner about 50/50 with water (follow manufacturer directions) and pour through the tube until the Generator is full. Allow the cleaner to work for a few minutes (follow manufacturer directions) and drain into a bucket or large container. Repeat this procedure one more time. Examine the drained cleaner and, if necessary, repeat until the drained cleaner is fairly clear.

Close the drain cock, fill the Generator with fresh water through the tubing, and drain. Repeat two more times. Turn power ON and flush for a minute or two. Close the drain cock, wait for the Generator to pump full, and close the drain cock. Turn power OFF and reconnect the tube to the flame arrestor. Be sure to top off the water tank.

### **Cold Weather Operation**

If outside temperatures are below freezing, isopropyl alcohol should be mixed with the water to prevent freezing. Since alcohol changes the dielectric properties of water, the HydroStar operating frequency must be changed by adjusting the "Frequency Adjust" trim pot for peak performance (refer to Figure 5 on page 13). Work is well underway to develop nichrome wire electric heating devices for cold weather operation. You will be notified when the devices, or plans for their construction, become available.

### **Spare Generator**

Because of its' great reliability and low maintenance factor, it's easy to forget that the HydroStar requires at least some periodic attention. Eventually the primary Generator may become clogged with mineral deposits due to neglected maintenance, or may even fail since nothing is perfect. Since such things always seem to happen at the worst possible moment, you may want to consider building and installing a spare Generator just to act as a backup. If you do, be sure to keep all dimensions the same as the primary Generator so that no retuning is needed. That way all you have to do is switch a few wires and tubes over to the spare Generator and you're back on the road.

### **Good Old Stainless Steel**

The only combustion product that your HydroStar powered engine produces is water (actually steam). And we all know what water, especially hot water, does to steel. Unless your engine has already been equipped with stainless steel valves, you should look into having them

installed as soon as possible to prevent valve corrosion problems (which could eventually lead to other much more serious problems). Stainless steel valves are relatively inexpensive, and almost any high performance shop can install them. Your exhaust system is also vulnerable to rust. But you have more options there. If the system is old, you may choose to let it eventually rust out and replace it with a stainless steel system. Or, if the system is new, any one of the new and readily available ceramic coating processes will prevent rusting. The most practical answer to the rust problem involves developing a water compatible additive that inhibits corrosion. Apparently such an additive is very close to being marketed; a liquid with a ratio of 3 parts additive to 100 parts water.

### **Fuel Injection**

The HydroStar system design is based on carburetor equipped engines. Extensive research and testing have not yet been done to test its' feasibility for use with fuel injected engines. But there's no reason why it should not perform just as well there. One obstacle involves making or modifying injection system components previously lubricated by a liquid (gasoline or diesel fuel) operable with a pure gas. Another obstacle is corrosion of the injector itself. But, as for exhaust systems, ceramic coating would be one solution; another would be stainless steel injectors. With the advent of hydrogen engines using fuel cells, both these problems have been overcome for specific applications, so hydrogen injection components may become "over the counter" items in the not too distant future. For the present, the simplest solution may be to simply covert fuel injected engines into carbureted engines (Impco can help out there), which are compatible with the HydroStar.

### **Good Old J-B WELD**

First chance you get, I recommend sealing the wire ends of all connectors with a high quality epoxy such as J-B WELD. Not only does this add physical strength to the connector, but helps seal against corrosion. This is especially effective for connectors inside the engine compartment. Use only a small amount of epoxy. Don't overdo it to the point that epoxy flows onto the connector contacts themselves.

### **Keep Close Watch**

Always keep an attentive eye on the CHT and pressure gauges. They can tell you a lot about how the system is performing at any particular

moment. Any sudden or unexpected change in temperature and/or pressure usually signals that a problem has occurred, or is about to occur. Eventually you'll develop a "feel" for interpreting the gauges.

## **Garretts' Gadget**

Here's a complete hydrogen/oxygen system (refer to Figure 22 on page 94) all wrapped up in a neat little package. It was an ingenious concept, all the basic elements are there. But it went the way of countless other inventors' dreams, doomed to fail only because of lack of vital technology. Charles Garrett originally patented this gadget back in 1932 (U.S. Patent 2,006,676), terming it an "Electrolytic Carburetor." He proposed charging the electrodes with a "storage battery," a hopelessly inadequate power source

Lead plates served as the water capacitor and weak sulfuric acid as electrolyte. Since the water chamber has to be electrically non-conductive, it was constructive of bakelite (an early-day form of plastic). An electric motor drove a gear with an offset pin and linkage, actuating a switch to reverse battery polarity to the plates. (Mechanically creating a very low frequency, low voltage, pulse.) Water level was mechanically controlled by means of a float and needle valve assembly designed to restrict the water inlet port.

Looking at the Garrett Gadget, we can see that the basic concept of a water powered engine is not a new idea by any means. He was on the right track; all he needed was 70 more years of evolving technology.

## **References**

Stephen Chambers, "Apparatus for Producing Orthohydrogen and/or Parahydrogen" U.S. Patent 6,126,794 and "Prototype Vapor Fuel System."

Stanley Meyer, "Method for Production of a Fuel Gas" U.S. Patent 4,936,961.

Carl Cella, "A Water-Fueled Car" Nexus Magazine, Oct-Nov 1996.

Peter Lindemann, "Where in the World is All the Free Energy."

George Wiseman, "The Gas-Saver and HyCo Series."

C. Michael Holler, "The Dromedary Newsletter" and "SuperCarb Techniques."

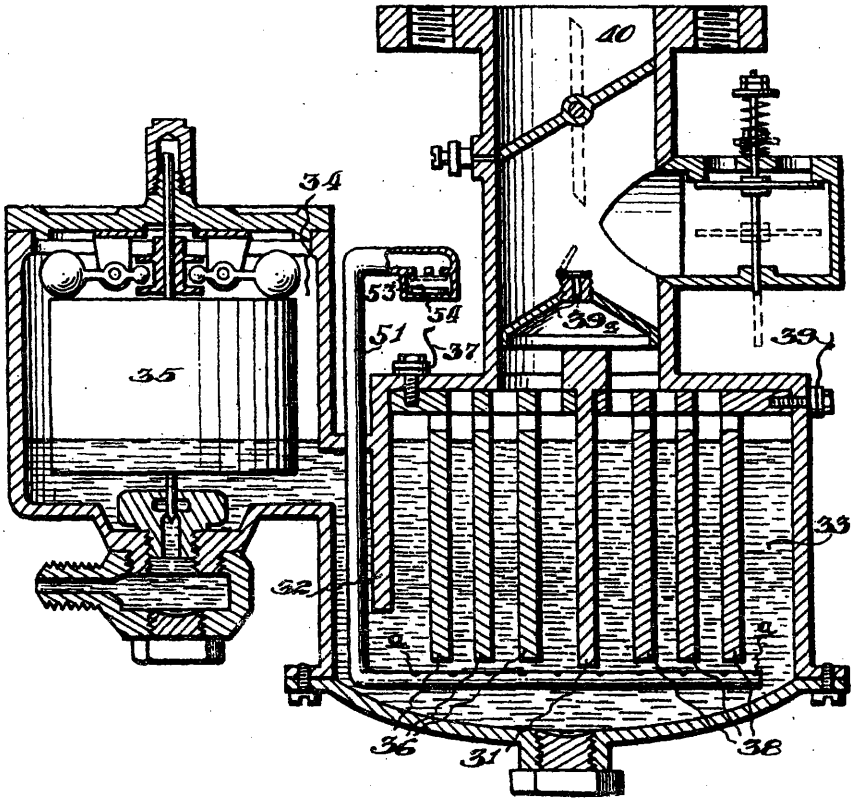

**Garrett's Gadget  
Figure 22**

Creative Science and Research, "Fuel From Water."

## **A Thought or Two**

During countless hours spent researching and compiling material for this book, I was constantly amazed at the ingenuity of the hundreds of patented inventions I happened upon. It's little wonder the United States always sets the worlds' technology pace. We're very fortunate to live in a country that encourages original ideas and provides such wonderful opportunities for putting them to practical use.

I hope you enjoy this book. It was a real challenge for me, but I had a great time putting it together. Don't forget to let me know about your experiences with your own HydroStar....and, Happy Driving!!

